



Sztuczna inteligencja i przyszłość cywilizacji.



Włodzisław Duch

Katedra Informatyki Stosowanej, INT WFAiIS UMK
Neuroinformatyka i Sztuczna Inteligencja, CD DAMSI
Laboratorium Neurokognitywne, ICNT
Google: Wlodzislaw Duch

Tydzień Mózgu 2021, Toruń 18.03.2021

CD DAMSI

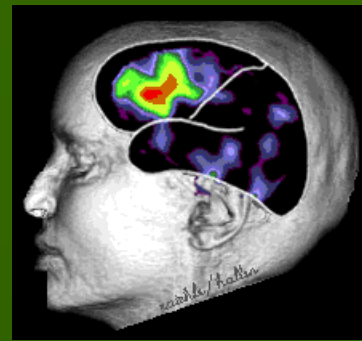

Uniwersyteckie Centrum Doskonałości (2020) w ramach IDUB
“Dynamika, analiza matematyczna i sztuczna inteligencja”.

- Dynamika i teoria ergodyczna.
- Informatyka – języki formalne i współbieżność.
- Neuroinformatyka i sztuczna inteligencja.
- Stany splątane i dynamika otwartych układów kwantowych.

Neuroinformatyka jest kombinacją dwóch ważnych dyscyplin na froncie nauki: badań nad mózgiem i sztucznej inteligencji. Wykorzystując metody uczenia maszynowego i przetwarzania sygnałów, rozwijane są nowe teorie i algorytmy analizy sygnałów mózgu, hipotezy weryfikowane za pomocą eksperymentów.

Nasza grupa: zrozumienie procesów w mózgu i inspiracje dla algorytmów AI.
Komitet Informatyki PAN: Sekcja Nauk Obliczeniowych, Bio- i Neuroinformatyki.

Epoki rozwoju cywilizacji



To nadzwyczajny moment w historii świata!

Rozwój rozumienia rzeczywistości:

1. Myślenie magiczne, kaprysy bogów, fatalizm.
2. Przyczynowość i empiryczne obserwacje, wiedza opisowa.
3. Teorie i rozumienie mechanizmów, weryfikacja, matematyka i statystyka.
4. Symulacje komputerowe i „nowy rodzaj nauki” Wolframa.
5. Wiedza z danych, gromadzenie i dostęp do wszystkich informacji.
6. Sztuczna inteligencja wspiera ludzkie myślenie.
7. Autonomiczna sztuczna inteligencja, nadludzkie możliwości.

5 paradygmatów rozwoju nauki wg IBM: empiryczny, teoretyczny, symulacyjny, wiedzy z danych (data driven), oraz przyspieszonych odkryć.

Coraz bardziej złożone modele: IBM Watson, CyC, GPT-3, Google Mixture of Experts (MoE), model z 1 trylionem parametrów ...

Inteligencja to tylko to, czego jeszcze nie potrafią sztuczne systemy AI?

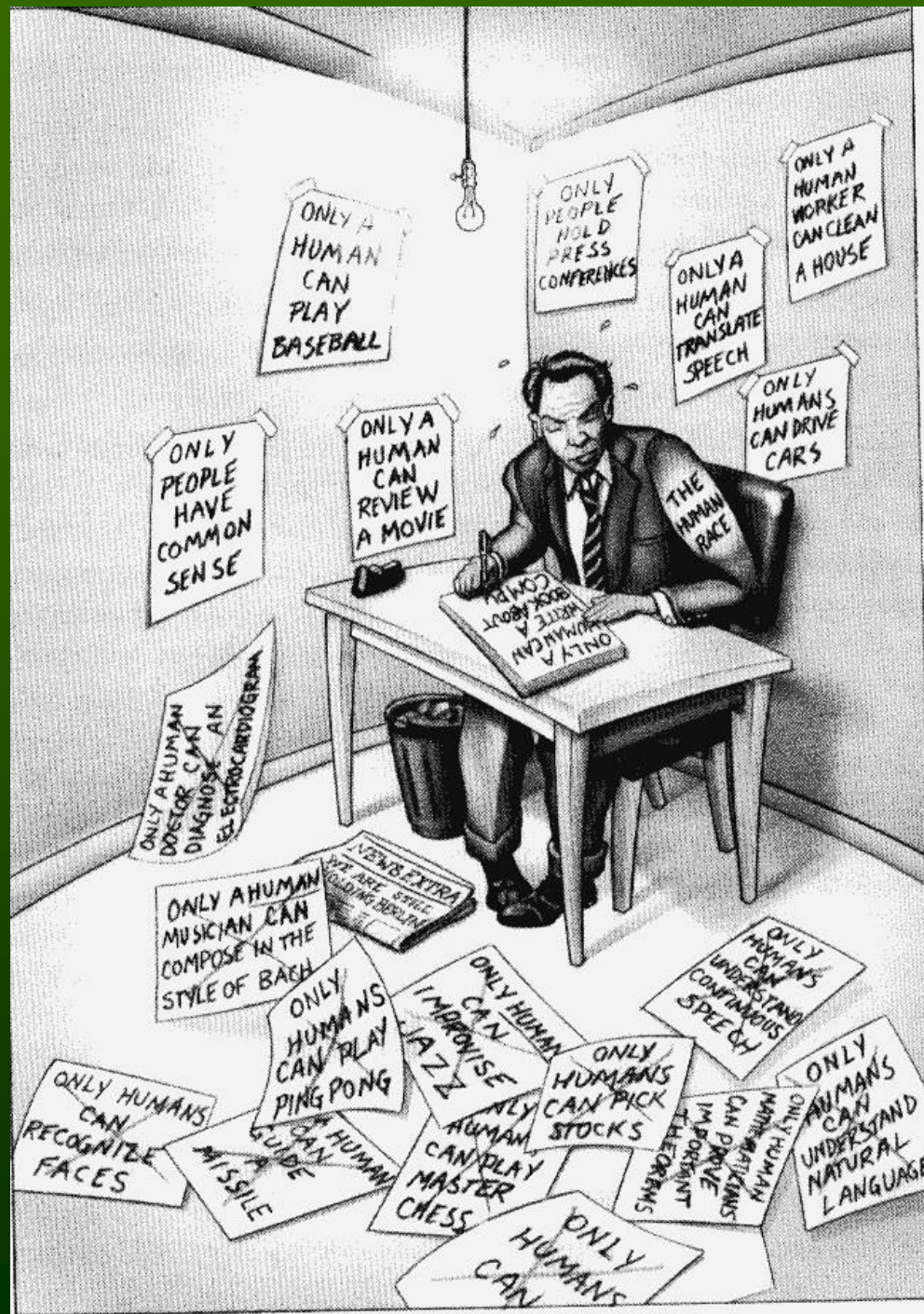
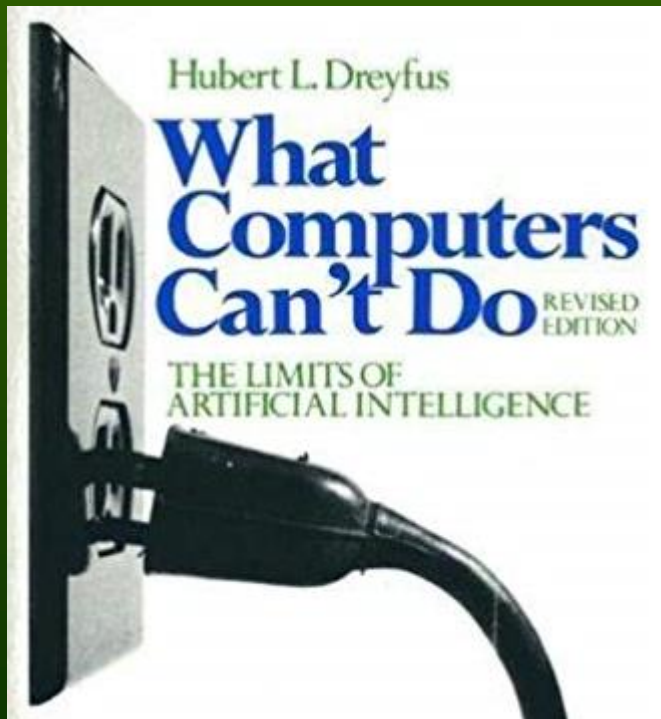

AI: definicja informatyka

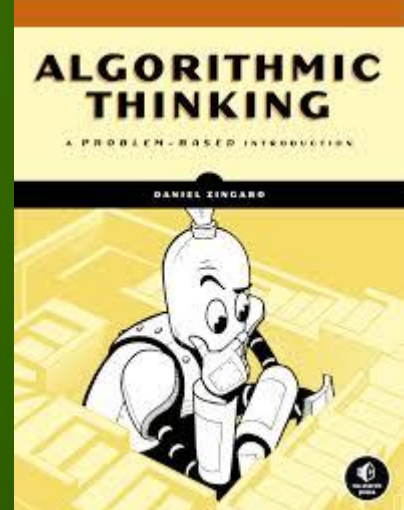

Sztuczna Inteligencja (Artificial Intelligence, AI) to dział informatyki zajmujący się rozwiązywaniem problemów, dla których nie ma **efektywnych algorytmów**.

Dawniej: w oparciu o modelowanie wiedzy, przedstawianej w werbalnie opisywany, symboliczny sposób, głównie zajmująca się rozumowaniem na poziomie koncepcyjnym.

Obecnie (ostatnie dekady): AI jest niemal utożsamiana z uczeniem maszynowym, czyli rozpoznawaniem obrazów, odkrywaniem wiedzy w dużych zbiorach danych, funkcjom realizowanym intuicyjnie. Najważniejsza technika: wielowarstwowe sieci neuronowe. Technologie **neurokognitywne**: **neuro => cogito**.

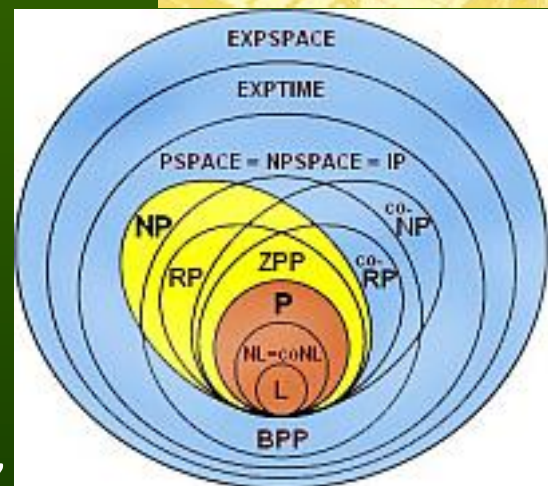

Regulacja AI? To jak regulacja matematyki. Reguluje się zastosowania.

Third wave of AI

The third wave of AI

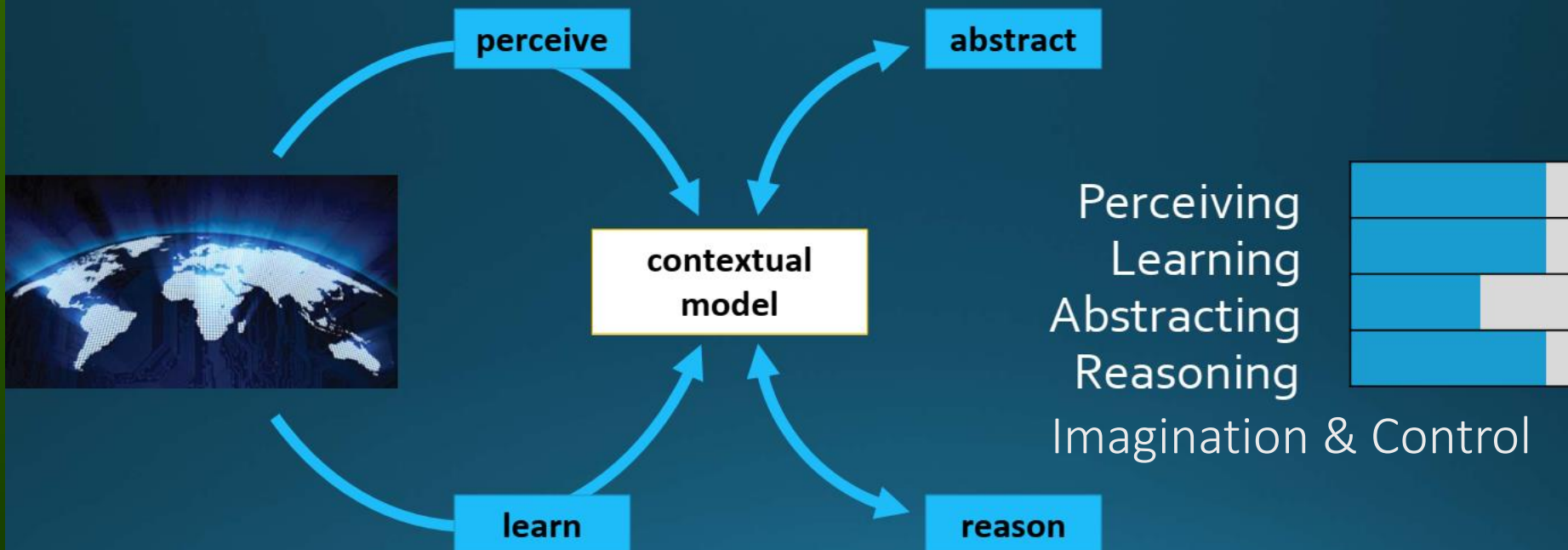

Pierwsza fala (1980): systemy regułowe, ekspertowe, klasyczne GOFAI.

Druga fala (2000): podejście statystyczne, oparte na dużej ilości danych, KDD.

2014: **GAN, Generative Adversarial Networks**, sztuczna wyobraźnia!

Gartner Hype Cycle

Emerging Technologies 2020

Expectations

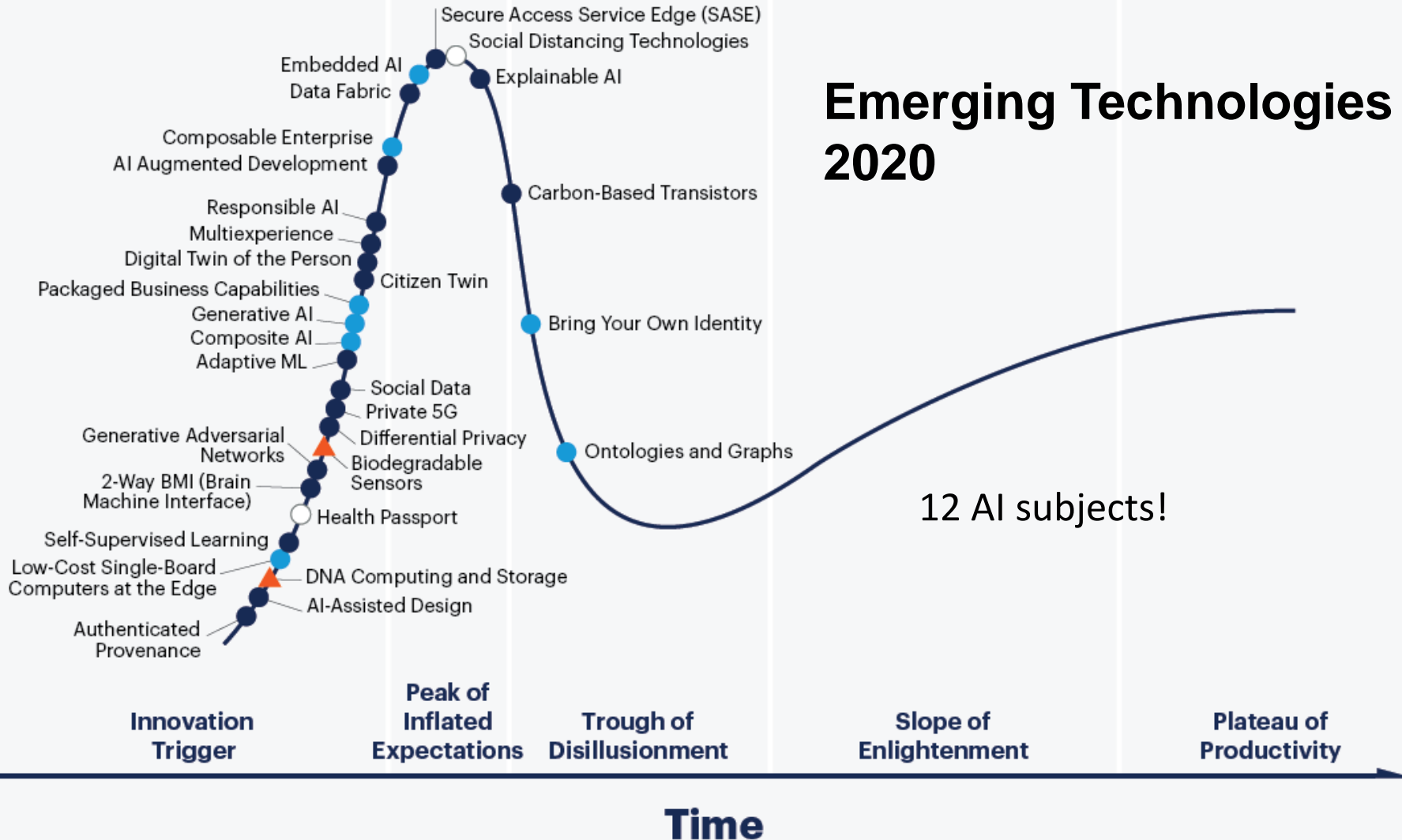

12 AI subjects!

Time

Plateau will be reached:

- less than 2 years
- 2 to 5 years
- 5 to 10 years
- ▲ more than 10 years
- ⊗ obsolete before plateau

As of July 2020

WEF: 4th Industrial Revolution driven by AI/neuro



3D Printing



Advanced Materials



Artificial Intelligence and Robotics

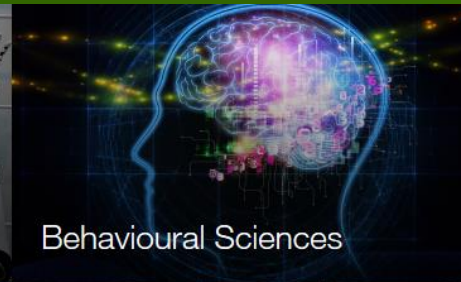

Behavioural Sciences



Blockchain



Drones



Fourth Industrial Revolution



Human Enhancement



Neuroscience



Precision Medicine

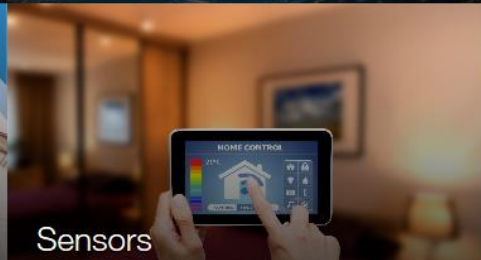

Sensors



Virtual and Augmented Reality



Internet of Things



Biotechnology

Centra doskonałości AI

Komunikat Komisji Europejskiej (4/2018): „Sposób w jaki podejmiemy do sztucznej inteligencji zdefiniuje rzeczywistość, w jakiej będziemy żyć.”

European Network of Artificial Intelligence (AI) Excellence Centers, €50m
Konsorcja (10/2020) – dobry wzór dla Polski?

- AI4Media: ethical and trustworthy AI, beneficial technology in the service of society and media.
- ELISE: invites all ways of reasoning, considering all types of data, striving for explainable and trustworthy outcomes.
- HumanE-AI-Net: supports technologies for human-level interaction, empower individuals with new abilities for creativity and experience.
- TAILOR: builds an academic-public-industrial research network for Trustworthy AI, combining learning, optimization and reasoning.
- VISION: to foster exchange between the selected projects and other relevant initiatives, ensuring synergy and overcoming fragmentation in EU.



Kogni Nauki kognitywne

Biohybrydy

Bio
Lab
neuro-
kognitywne

Nano
Fizyka
Kwantowa

Info

Informatyka, inteligencja obliczeniowa/sztuczna,
uczenie maszynowe, sieci neuronowe

Neuromorficzna przyszłość

Ta ściana mieści 1024 chipy TN, czyli 1 mld neuronów i 256 mld synaps.
1/4 mózgu goryla, 1/6 szympansa. Cerebras CS-1 chip ma 1200 mld tranzystorów!

Integracja:

Nano +

Neuro +

Info +

Kogni

Neural AI
accelerators.

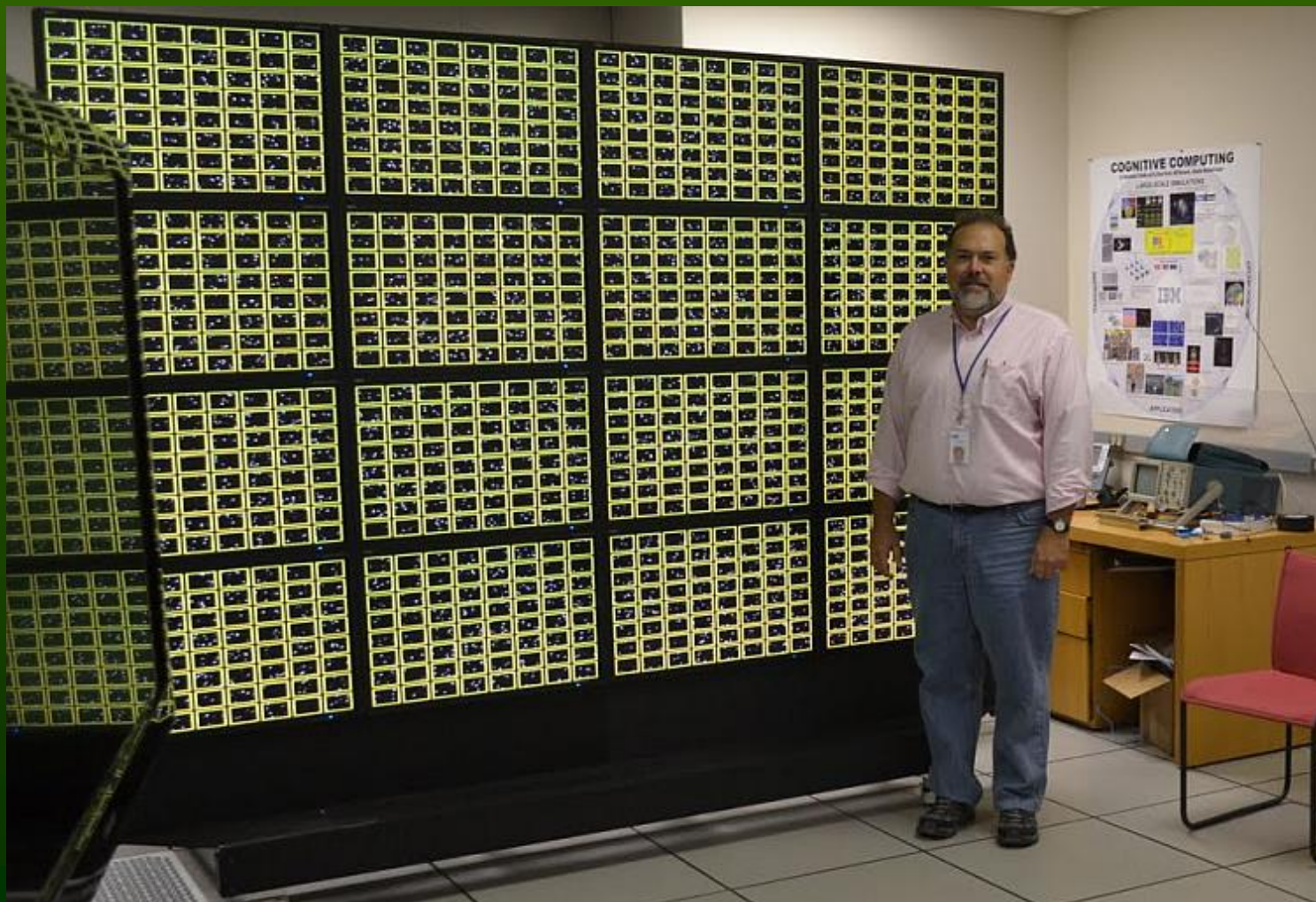

Nano: hybrydowe chmury

Science is moving beyond dedicated advanced compute systems to make greater use of hybrid cloud: local, public & private, traditional + new ways of computing.

Heterogeneity to support seamless workflows across highly diverse resources including scientific instruments, sensors, physical devices, and entire labs and research organizations.

Distributed farms, data flow machines, FPGA, quantum computing, neuromorphic computing, high-end network ...

European Open Science Cloud (2018) [Helix Nebula Science Cloud](#) run by CERN.

U.S. Department of Energy's Research Hybrid Cloud at Oak Ridge National Lab

[COVID-19 High Performance Computing](#), huge consortium donating free computer time: 50.000 GPUs, 6.8 mln cores, 600 Pflops, 100 projects.

43 consortium members: USA national labs, NASA, NSF, NIH, Amazon, Google, Dell, HP, Intel, Microsoft, Nvidia, RIKEN ...

The COVID-19 High Performance
Computing Consortium



Nadludzkie możliwości AI



Rozumowanie: 1997–szachy, Deep Blue wygrywa w szachy; 2016 –AlphaGo wygrywa w Go;

Percepcja: rozpoznawanie twarzy, obrazów, cech osobowości, preferencji seksualnych, politycznych ...

Strategia i sterowanie: 2017–OpenAI wygrywa w Pokera i Dota 2; 2019-Starcraft II ... co zostało?

Eksperymenty naukowe: 2015-AI odkrywa ścieżki genetyczne/sygnałowe regeneracji płazińców. 2020-AlphaFold 2 zwiija białka.

Robotyka: 2020 fikołki i parcour Boston Dynamics, autonomiczne pojazdy na drogach.

Kreatywność i wyobraźnia: AIVA i inne programy muzyczne, DeepArt i programy malarskie.

Język: 2011–IBM Watson wygrywa w Jeopardy (Va Banque); 2018–Watson Debater wygrywa z filozofami, 2020: BERT odpowiada na pytania z bazy SQuAD.

Cyborgizacja: BCI, optymalizacja mózgow, jeszcze nie.



Artificial General Intelligence (AGI), Memphis 2008



AlphaGo Zero uczy się Go od 0!

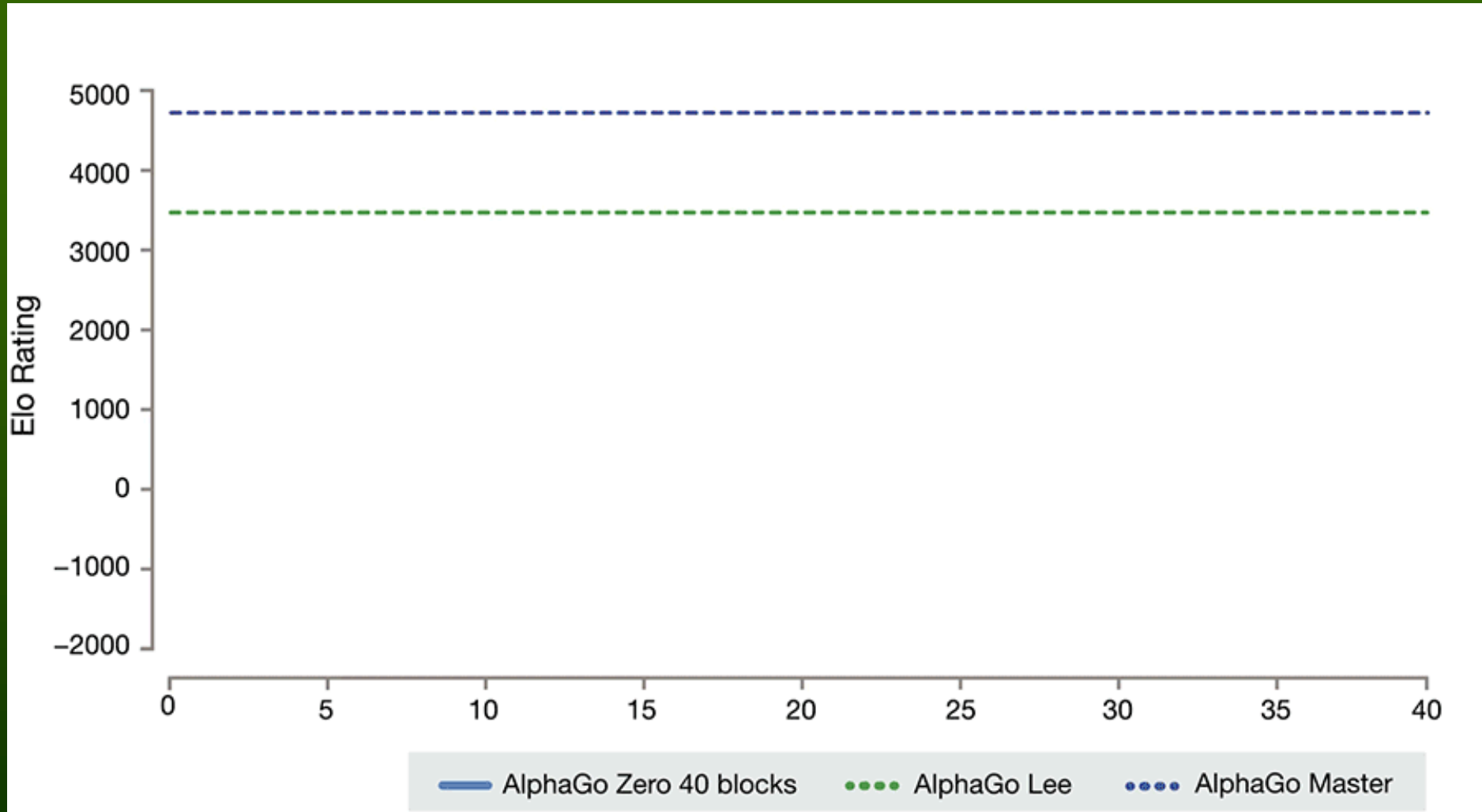

Tysiące lat ludzkiego doświadczenia odkryte w kilka dni dzięki graniu przeciwko sobie, pozwala osiągnąć nadludzkie możliwości w strategii gry w Go.

Nadludzka percepcja

Automatyczna analiza zdjęć twarzy określa własności fizyczne: płeć, wiek, rasę, BMI, choroby.

Niespodzianka! Również emocje, cechy charakteru, skłonności kryminalne, preferencje religijne, polityczne i seksualne można odczytać z twarzy z większą dokładnością niż robią to ludzie.

Homo/hetero mężczyźni w 91% przypadków, a kobiety w 83% (5 zdjęć/osobę). Oceny 35 ludzi były poprawne w 61% i 54% .



Analiza ponad miliona zdjęć pozwala na poprawne określenie preferencji liberalnych vs konserwatywnych w 72% przypadków. Ludzie - 55% poprawnych. Tendencje kryminalne: dla 5000 więźniów i tyle samo kontrolnych zdjęć sieć CNN wykazała 97% dokładność (pracę wycofano, brak zgody komitetu etycznego).

Preferencje wymalowane na twarzy?

Analiza zdjęć twarzy >1M osób pozwoliła na rozróżnienie w 72% liberalno-konserwatywnej orientacji; sędziowie 55% (M. Kosiński, Sci. Rep. 2021).

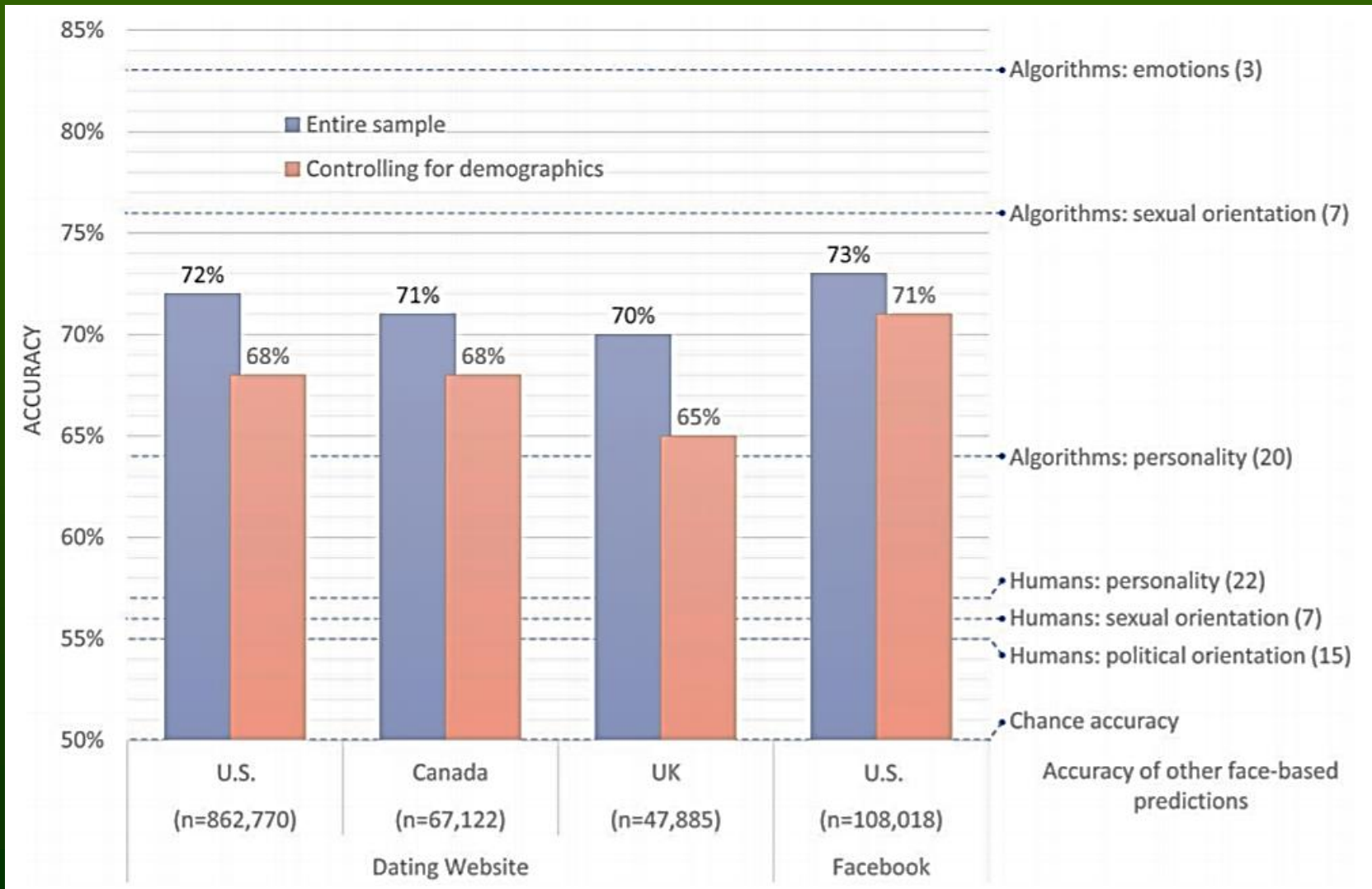

Kontrola: sterowanie robotami

Inteligencja behawioralna: nauka robota od “niemowlęctwa”.

Projekt Cog na MIT, Rodney Brooks lab, 1994-2003. Projekt iCube

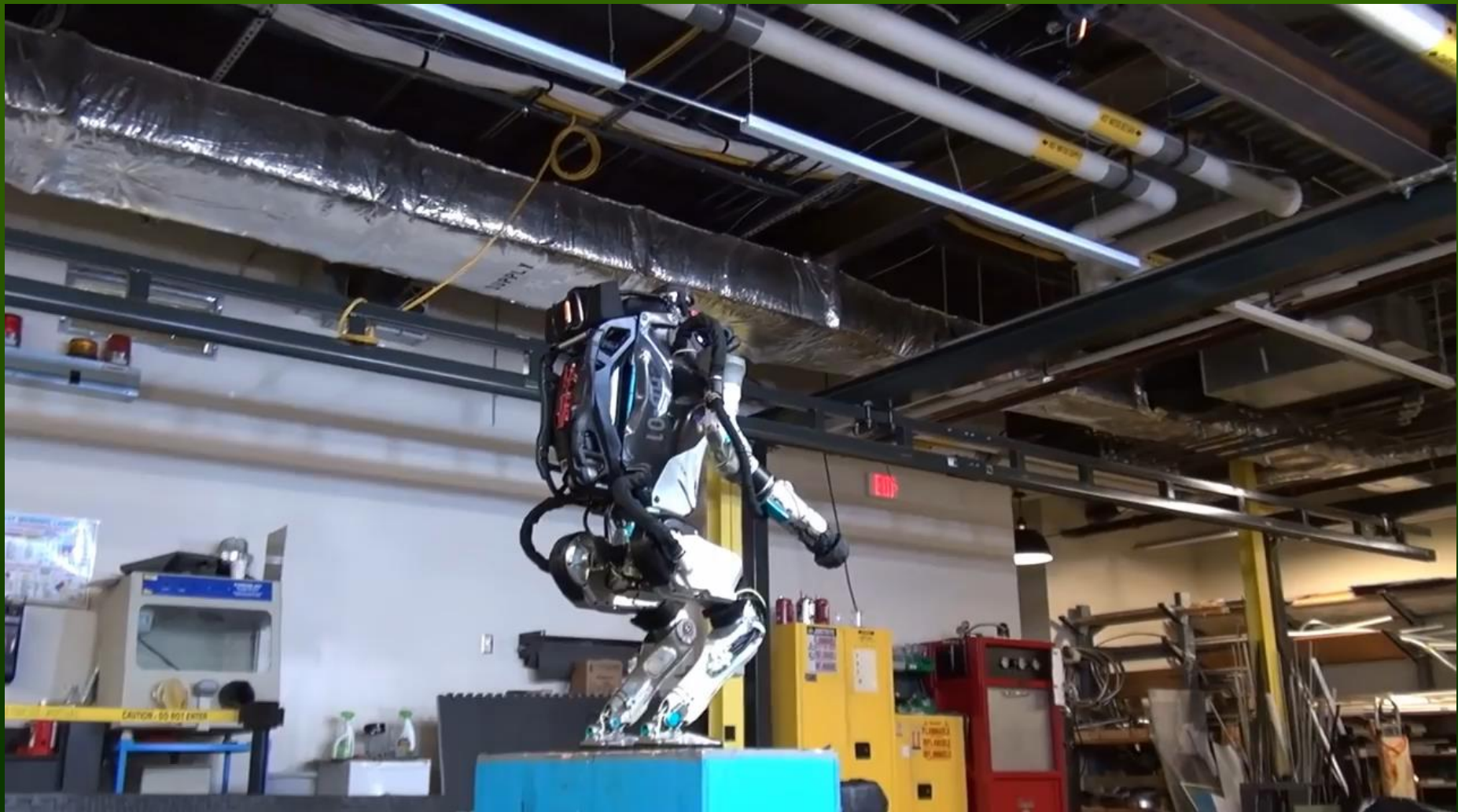

GAN, Generative Adversarial Networks

Idea (2014): jedna sieć generuje fałszywe przykłady zniekształcając dane treningowe, druga ocenia czy to prawdziwe dane. Zobaczyć i nie uwierzyć!



2014

2015

2016

2017

Text description

This bird is blue with white and has a very short beak

This bird has wings that are brown and has a yellow belly

A white bird with a black crown and yellow beak

This bird is white, black, and brown in color, with a brown beak

The bird has small beak, with reddish brown crown and gray belly

This is a small, black bird with a white breast and white on the wingbars.

This bird is white black and yellow in color, with a short black beak

Stage-I images

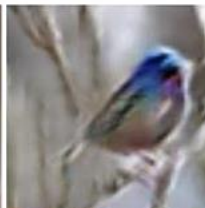
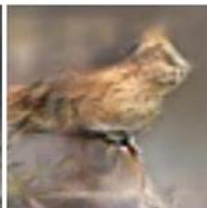
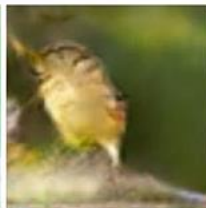

Stage-II images



GAN-animacja

Obrazy można ożywić lub zamienić automatycznie w karykatury.
Realistyczny model wymaga kilku zdjęć lub obrazów.
Można też dodać różną ekspresję imitując osobowość i głos.

Living portraits



Gender swap of composers czyli AI zmienia płeć!
Bez pigułek wrzucanych po kryjomu do tornistrów dzieci!

Deep fake video

Każdy może stworzyć „deep fake”.

Można też dodać różną ekspresję imitując osobowość i głos.

Deepfake Videos Are Getting Real, Gender swap of composers

Google Deep Dream, czyli androidy śnią o elektrycznych owcach!



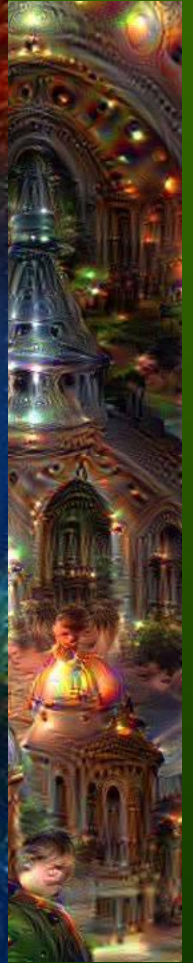

[Google Deep Dream/Deep Style & Generator, Gallery](#)

LA Gatys, AS Ecker, M Bethge, A Neural Algorithm of Artistic Style (2015)

Kreatywność: AI Virtual Artist

AIVA – AI Virtual Artist, przyjęty do SACEM (Stowarzyszenie Autorów, Kompozytorów i Wydawców Muzycznych Francji), 239 utworów.

AIVA YouTube channel, Youtube „Letz make it happen”, Op. 23

SoundCloud channel Spotify i Apple channel

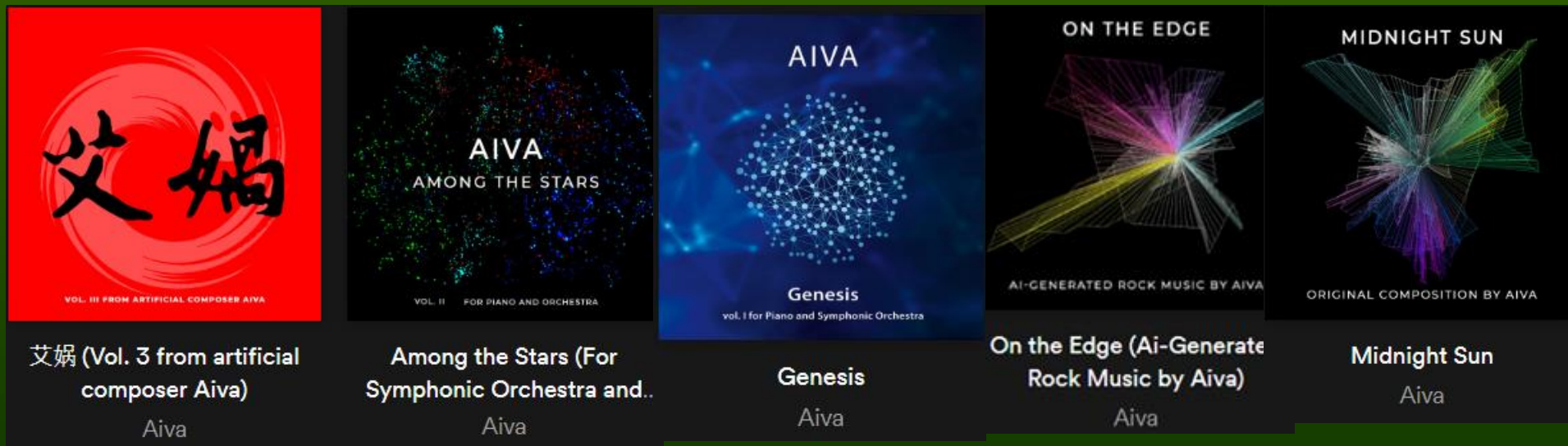

Duch W, Intuition, Insight, Imagination and Creativity.

IEEE Computational Intelligence Magazine 2(3), August 2007, pp. 40-52

Kontrola: sterowanie robotami

Inteligencja behawioralna: nauka robota od “niemowlęctwa”.

Projekt Cog na MIT, Rodney Brooks lab, 1994-2003. Projekt iCube

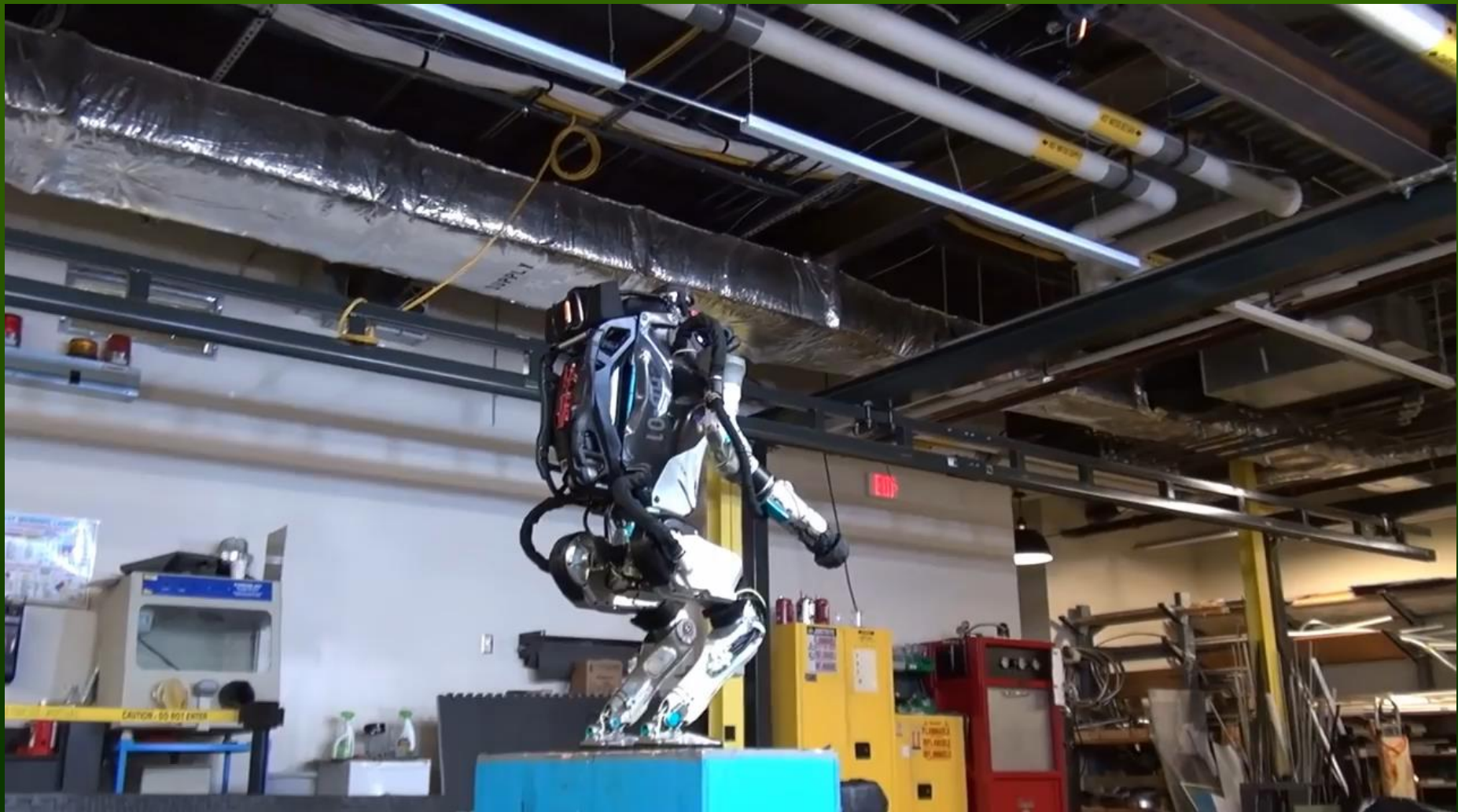

Zwijanie białek



AlphaFold 2 wykorzystując głębokie uczenie przewiduje ponad 2/3 struktur białek z dokładnością równoważną eksperymentalnej!

[Nature, 30.11.2020](#)

Rozpoznawanie struktur + uczenie się + wnioskowanie.

Przewidywanie struktur białek na podstawie sekwencji aminokwasów jest podstawą poszukiwania białek i projektowania leków o pożądanych własnościach.

STRUCTURE SOLVER

DeepMind's AlphaFold 2 algorithm significantly outperformed other teams at the CASP14 protein-folding contest — and its previous version's performance at the last CASP.

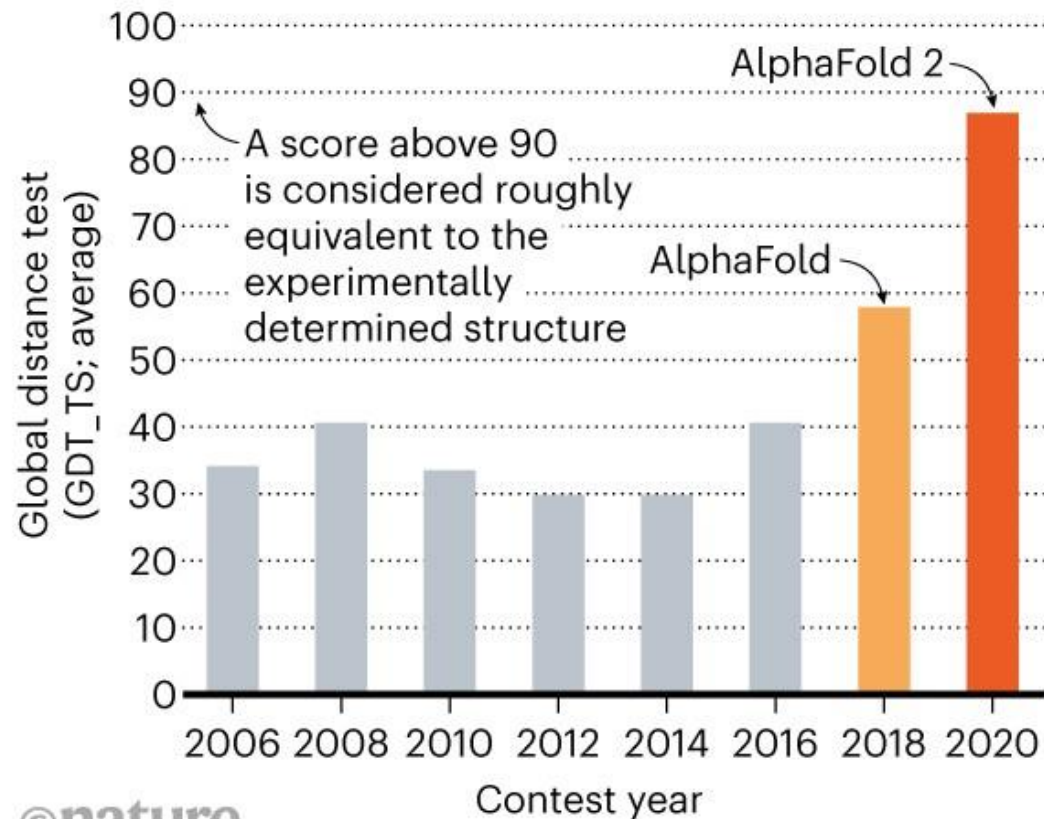

S. Lem: O królewiczu Ferrycym i królownie Krystali.
Inteligentne bladawce? Czy to możliwe?

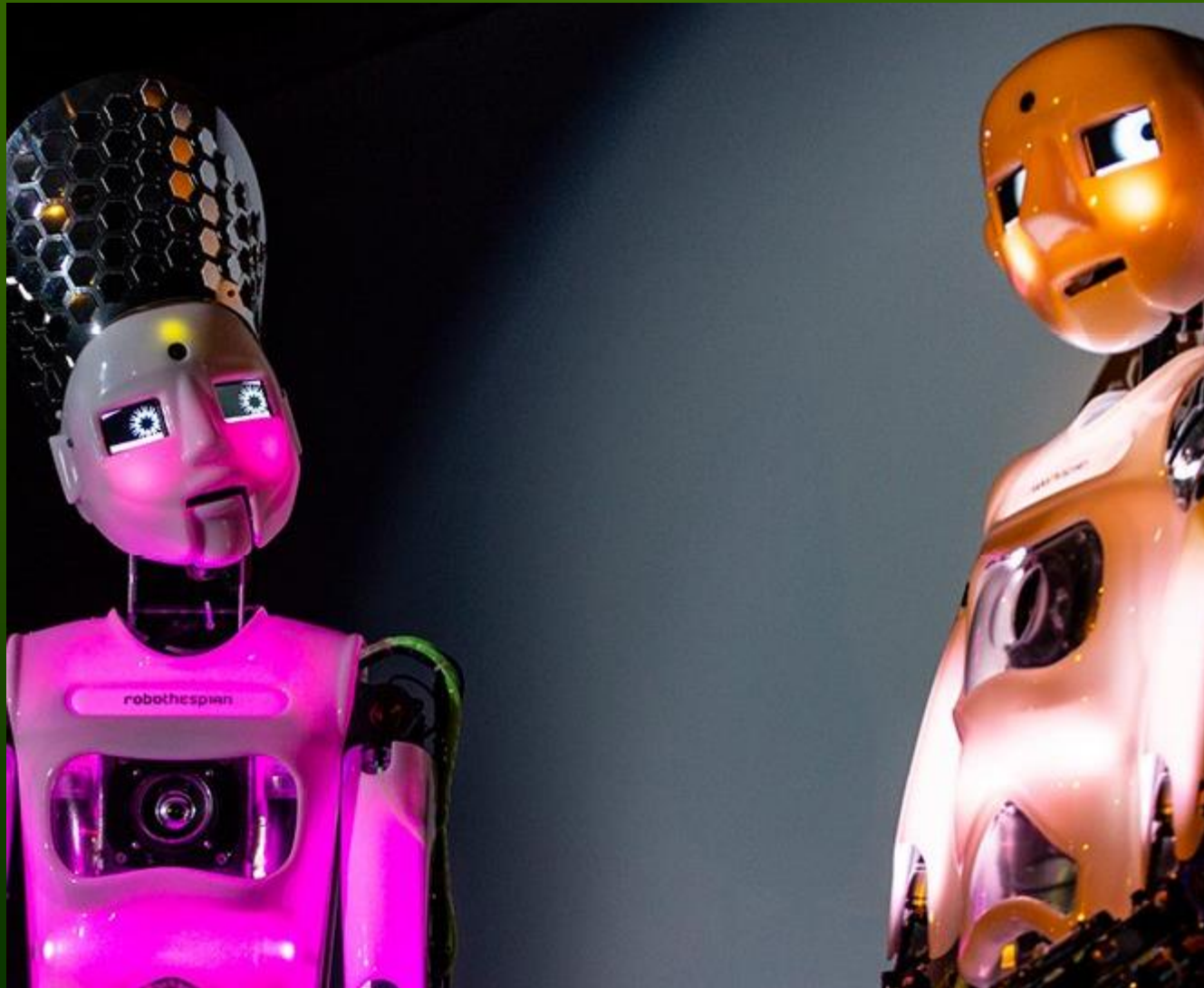

Wystarczy wybrać metodę ...

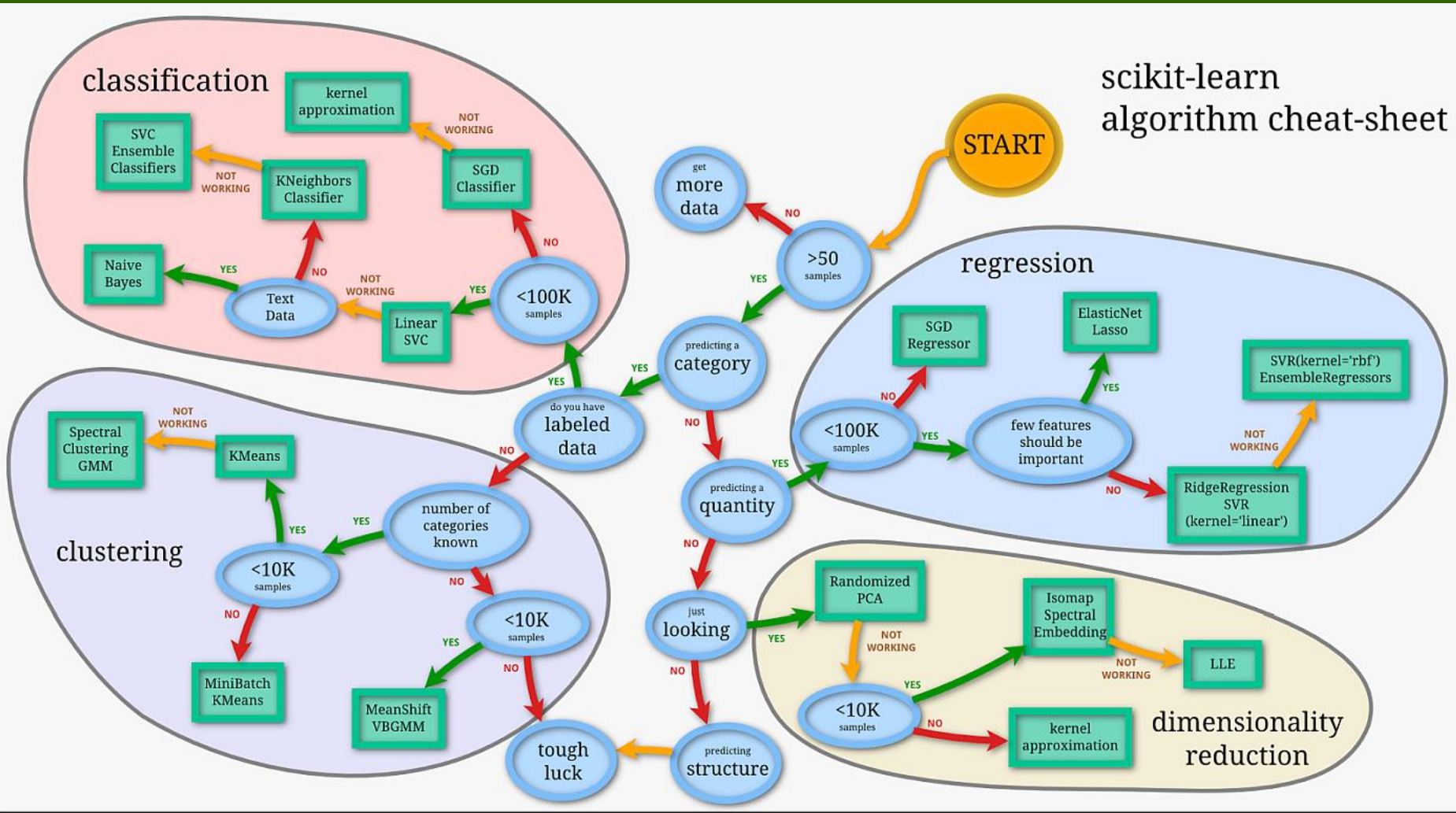

Zastosowania metod uczenia maszynowego są coraz łatwiejsze, mamy setki darmowych programów z wieloma algorytmami, tysiące aplikacji.

Sieci Neuronowe: Selfridge's Model (1959)

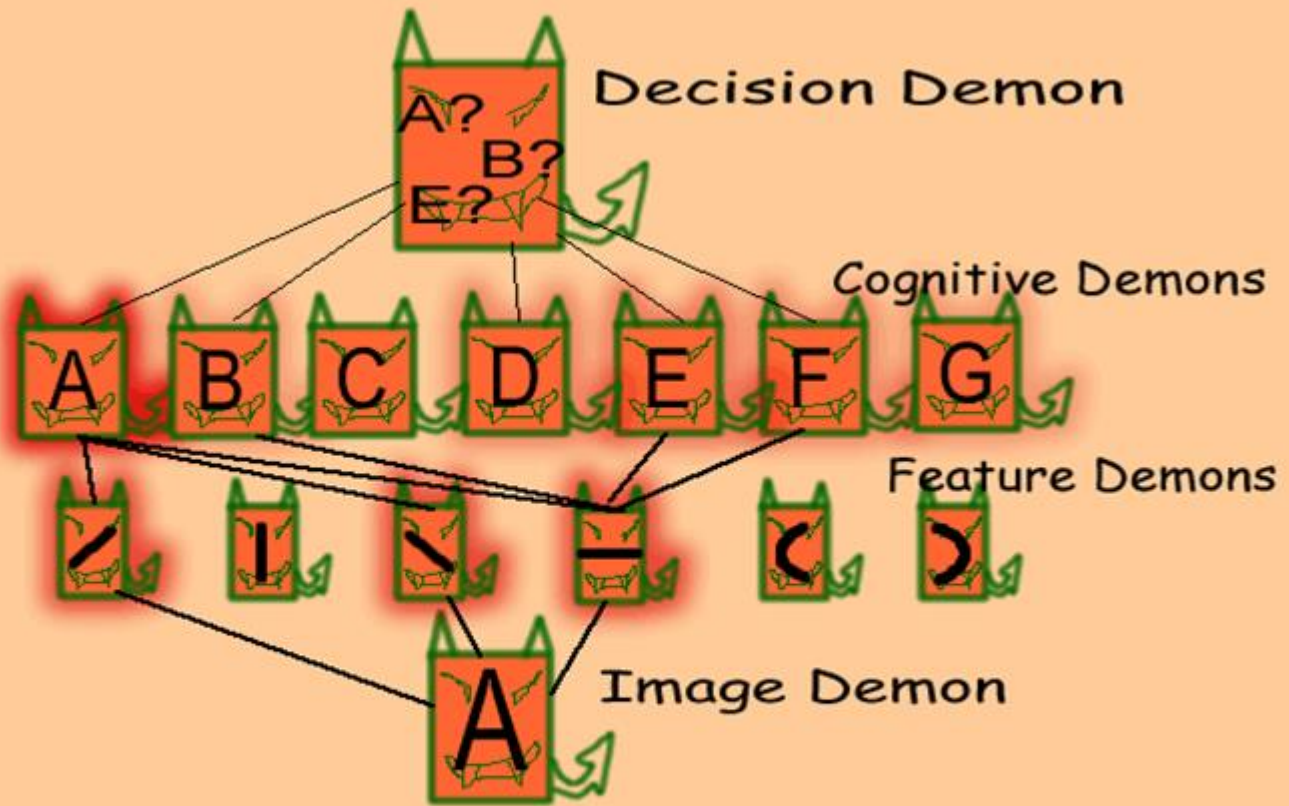

Based on:

Selfridge, O. G. (1959). *Pandemonium: A paradigm for learning*. In *Symposium on the mechanization of thought processes* (pp. 513-526). London: HM Stationery Office.

A Sensory Stimulus

NN dla obrazów: transformacje

Feature representation



3rd layer
"Objects"

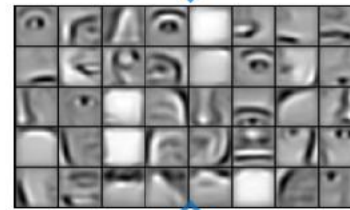

2nd layer
"Object parts"

Input data

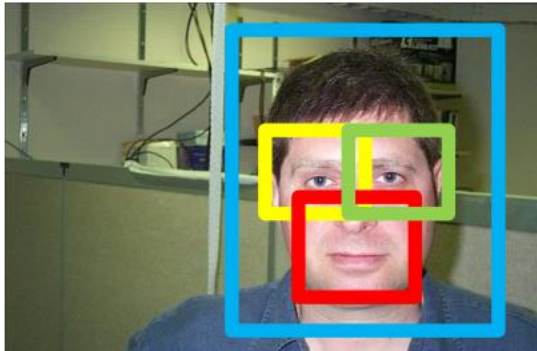

Feature maps

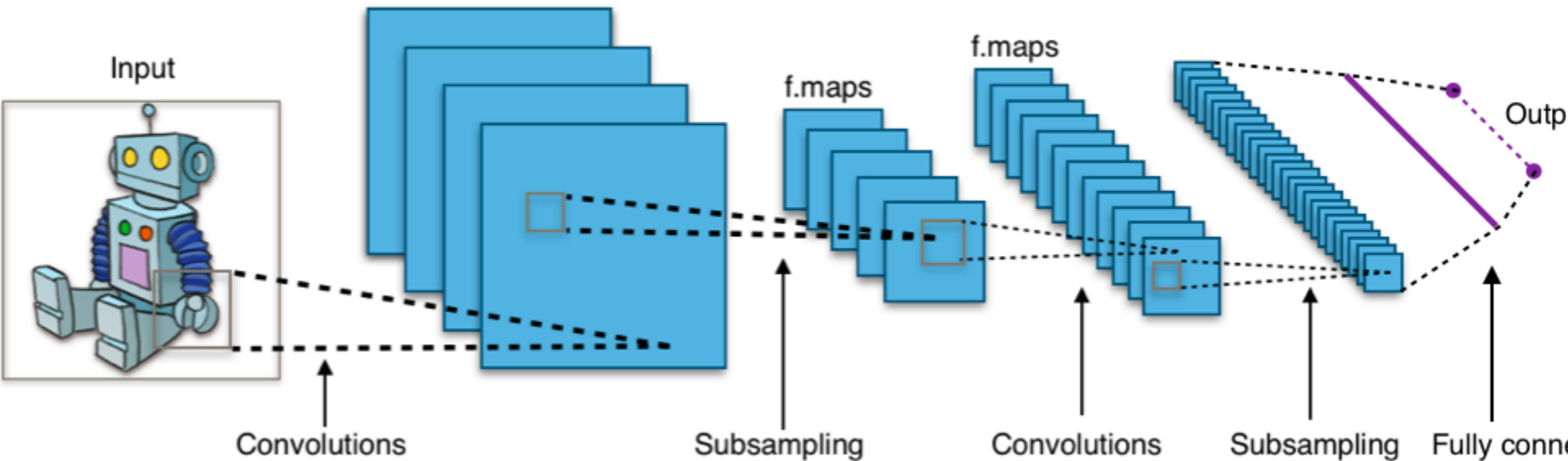

Tensorization of Convolutive Deep Learning NN

Większość sieci neuronowych to wiele prostych elementów, realizujących elementarne nieliniowe funkcje (np. kawałkami liniowe ReLu), wymieniające informacje przez ustalone połączenia, korygujące adaptacyjne współczynniki by nauczyć się transformacji. Algorytmy uczenia (backprop) nie mają dobrych biologicznych podstaw.

Ex: tensor networks
Cichocki Lab, RIKEN BSI

[WD: Support Feature Machines](#) (2011).

Nie wiemy jak używać oscylatorów do obliczeń.

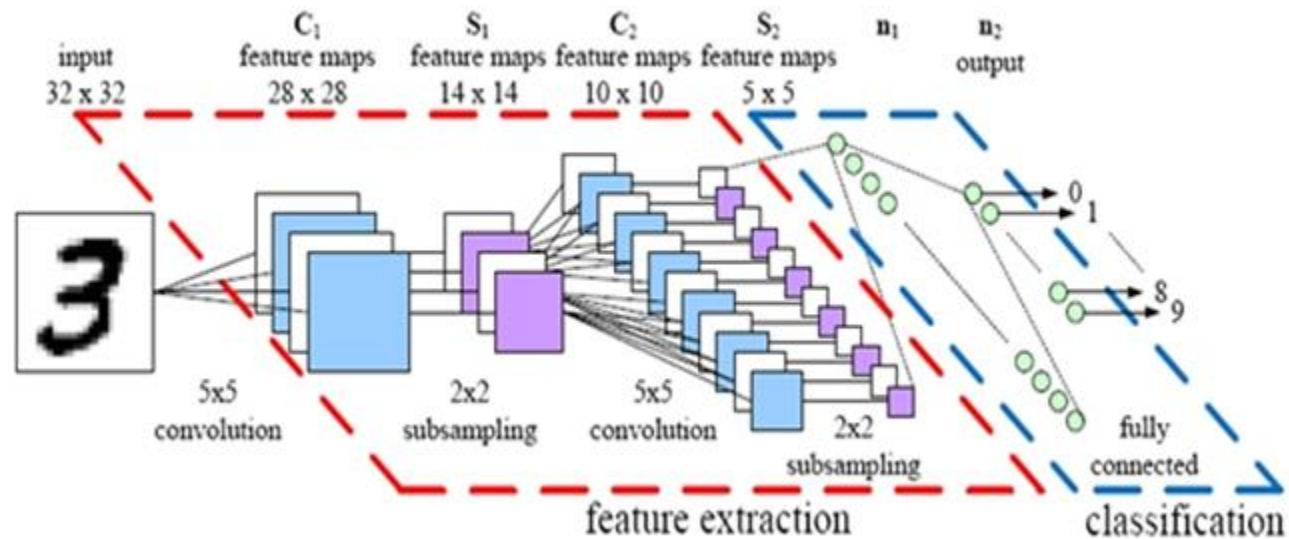
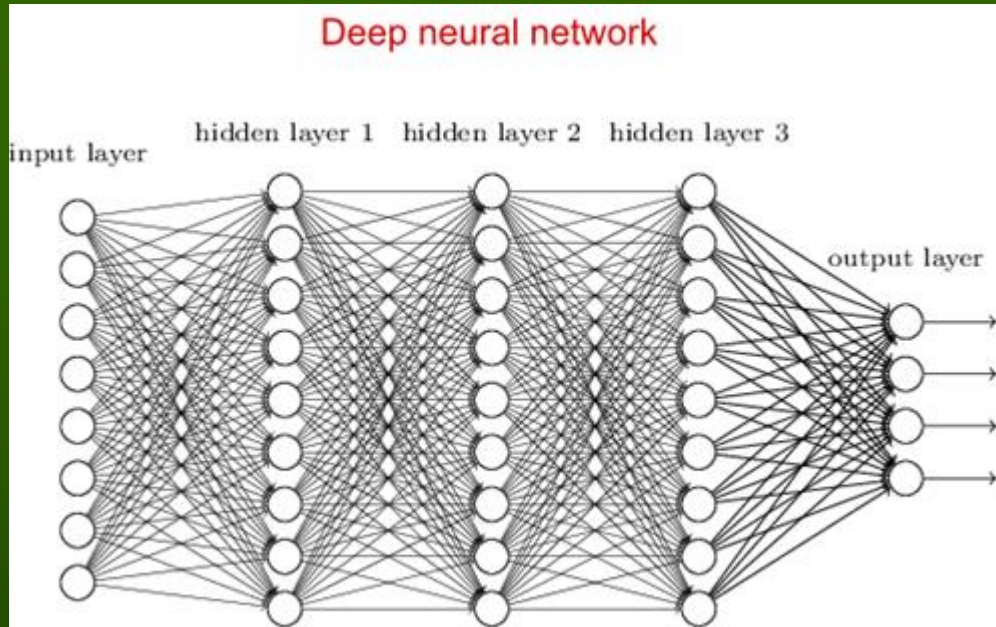

Neurony

Najprostsza inspiracja: neurony (100 G) => funkcje progowe $\sigma(W*X+\theta)$

Biologia: wiele rodzajów, kanałów jonowych, neurochemia, skomplikowana integracja czaso-przestrzenna, >10 K wejść ...

Szczegółowe biofizyczne modele neuronów potrzebne są by modelować wpływ leków, neurotransmitterów, zaburzenia psychiczne.

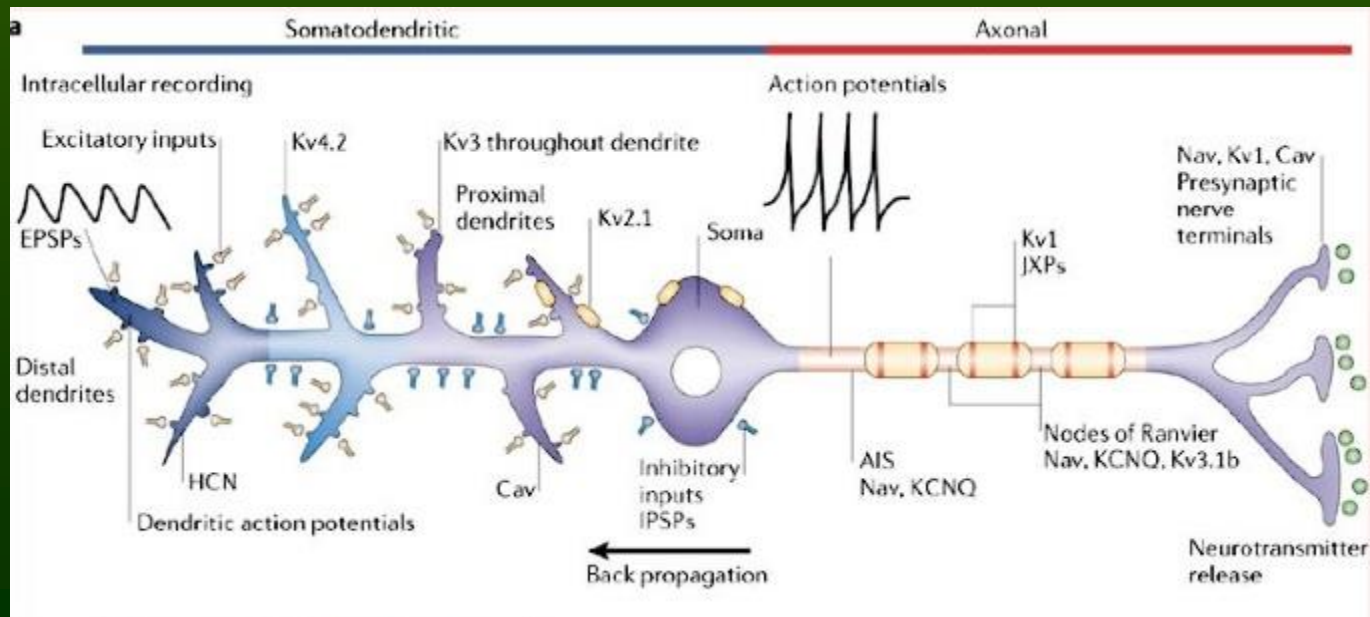
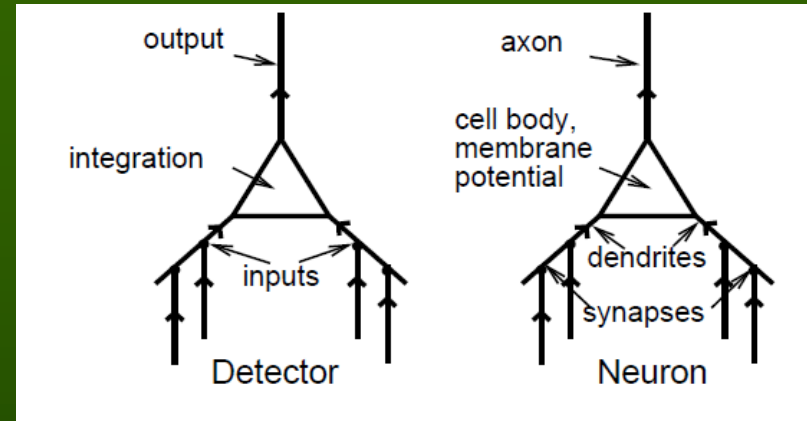

The Society of Mind

NN people ignored AI people (and vv). Will more sophisticated version of pandemonium – based on deep learning – lead to AGI?

The Society of Mind (Minsky 1986) presents theory of natural intelligence based on interactions of mindless agents constituting a “society of mind”, or multi-agent model, but at the symbolic level.

Duch W, Mandziuk J, *Quo Vadis Computational Intelligence?* Advances in Fuzzy Systems - Applications and Theory Vol. 21, World Scientific 2004, 3-28.

Minsky+Papert – MLPs is universal approximator but cannot solve connectedness problem.

⇒ NCE, modules, more internal knowledge, adding phase solves it, opens new complexity problem class.
This shows importance of various transfer functions and led to the FSM model with separable transfer functions.



Brain Inspirations



1. Simple neurons, 1 parameter, fixed synaptic connections
⇒ perceptrons, MLPs.
2. Complex neurons: microcircuits, small neural cortical ensembles with structural connections (fixed, or slowly changing).
3. Complex network states: rich internal knowledge in modules interacting in a flexible way, functional connections activated by priming, working memory control. Attractors of neurodynamics that synchronize many cortical ensembles, solving novel combinatorial problems.
4. **Society of minds**: for different tasks using flexible arrangement of functional connections between specialized brain regions, a lot of knowledge in such modules, no fixed connections.
5. **Society of brains**: collaboration between brains on symbolic level.

These inspirations led me to creation of many interesting ideas and algorithms. Some ideas are now verified experimentally using neuroimaging.

Studies in Computational Intelligence 63

Włodzisław Duch
Jacek Mańdziuk (Eds.)

Challenges for Computational Intelligence

 Springer

Studies in Computational Intelligence 358

Norbert Jankowski
Włodzisław Duch
Krzysztof Grąbczewski (Eds.)

Meta-Learning in Computational Intelligence

 Springer

Studies in Computational Intelligence 498

Krzysztof Grąbczewski

Meta-Learning in Decision Tree Induction

 Springer

Meta-uczenie, czyli jak się uczyć by się móc uczyć, odkrywanie nowych modeli. Transformation-based learning, Support Feature Machines, Universal Learning Machines i wiele innych ciekawych pomysłów – prace [na tej stronie](#).

AI for science

Science cycle

1. Explore the scientific literature

Find the most relevant papers in a sea of millions, track new topics as they emerge.



Semantic Scholar

A search engine that extracts not just words from papers, and "influential"

Iris.AI

A browsing tool for scientific paper concepts that

2. Design experiments

Find the right trade-off between exploration of ground and exploitation of well-trodden phenom

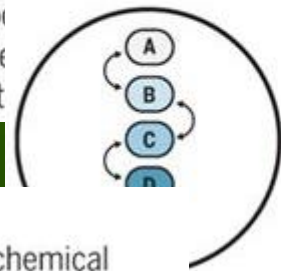

Zymergen

A company with an AI that tracks thousands of variables while trying to grow a new microbe genome (main story, p. 18)

3. Run experiment

Keep track of thousands of tiny tubes, molecules, and cells, minimizing the imprecision and mistakes that ruin careers.



Transcriptic, Emerald Cloud Lab

Cloud-based robotic laboratories for remotely doing automated molecular and cellular biology experiments.

4. Interpret data

Make sense of the flood of genetic and biochemical results that now flow from biological experiments.

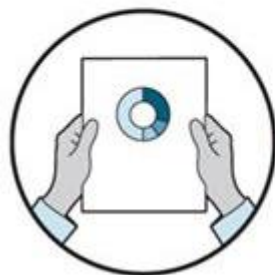

Nutonian

A software platform that ingests very large data sets and spits out a mathematical theory that explains the patterns in the data.

5. Write scientific paper

So far the closest thing to a paper-writing AI is a postdoc. But even writing papers can be enhanced with software that can read the draft of your paper.

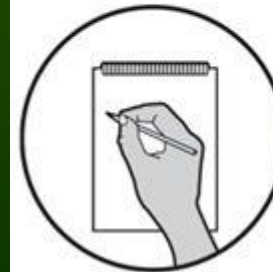

Citeomatic

A free online tool that reads your paper and predicts what citations are missing.

HOW MUCH OF SCIENCE can be delegated to machine-learning systems?

Science 2017, Cyberscientist: ... the ultimate goal is "to get rid of human intuition".

Discovery bottlenecks



Human-expert-driven and episodic, depending on the field of study.

- **Finding good questions** require increasingly deep and broad expertise.
- **Flood of scientific papers** and growing knowledge: > 2 million articles in 30,000 scientific journals each year, >74,000 new COVID-19 papers added to the PubMed in 2020.
- **Challenges in developing hypotheses:** there are about 10^{63} potential drug-like molecules, our knowledge is incredibly sparse compared to that.
- There are **gaps in testing**, including bridging digital models/physical testing.
- **Ensuring reproducibility** is hard, especially in social science, medicine, psychology: 70% of scientists have at least once failed to replicate experiments of other scientists. Statistics conceals individual differences.
- Scale-out, or **translation into practice** is slow.

AI enables knowledge extraction, integration, reasoning at a large scale with knowledge from real data. The steps in scientific method are accelerating.

Speed-up, scale-up and scale out!

Garuda Tools from SBI

Garuda: discover tools for data and the scientific questions you wish to address.

Accelerated discoveries!

AI tools support discovery process at every step, from questions to reports.

Labworm list of tools.

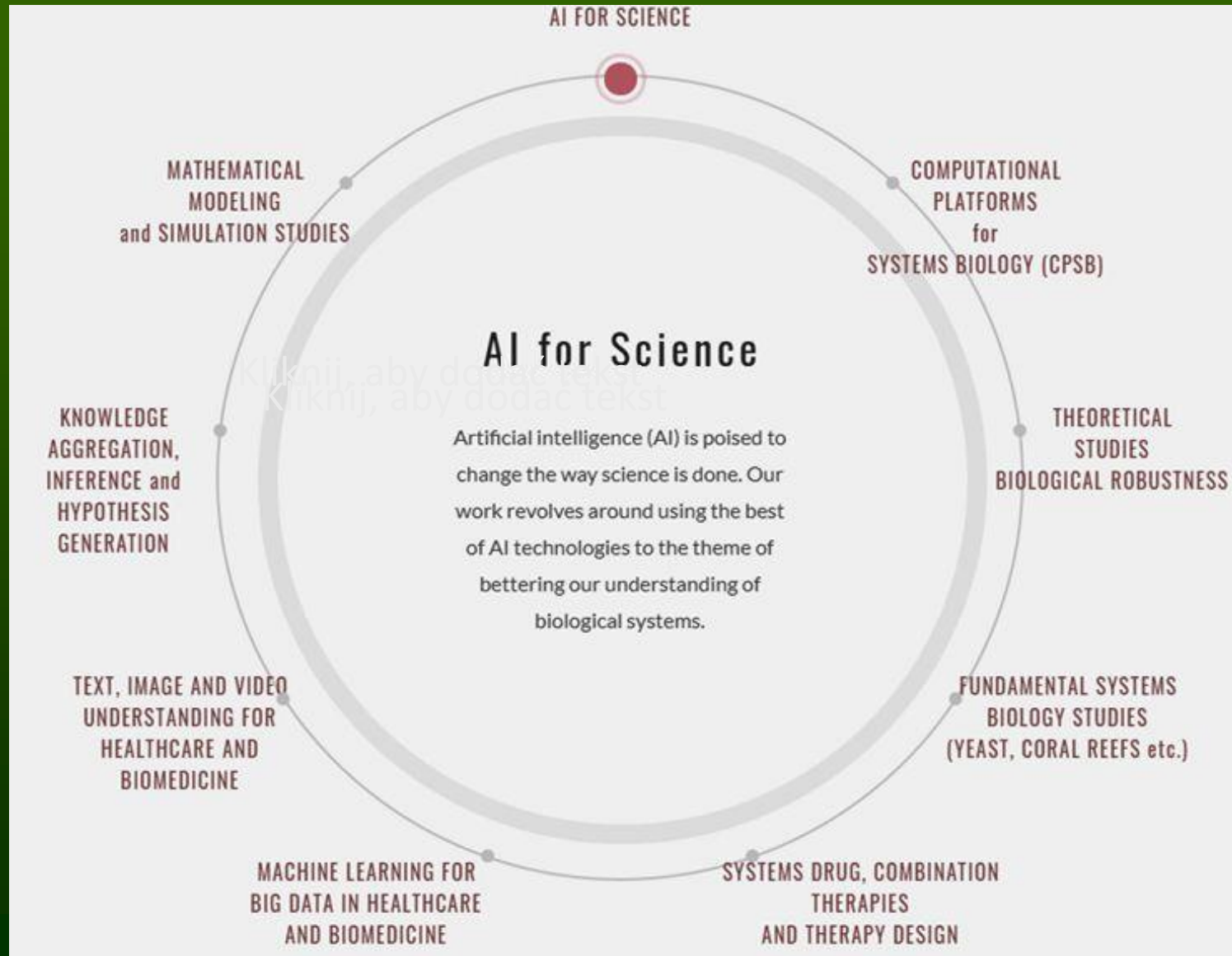

Accelerated discoveries (IBM)

IBM example: AI support in materials design.

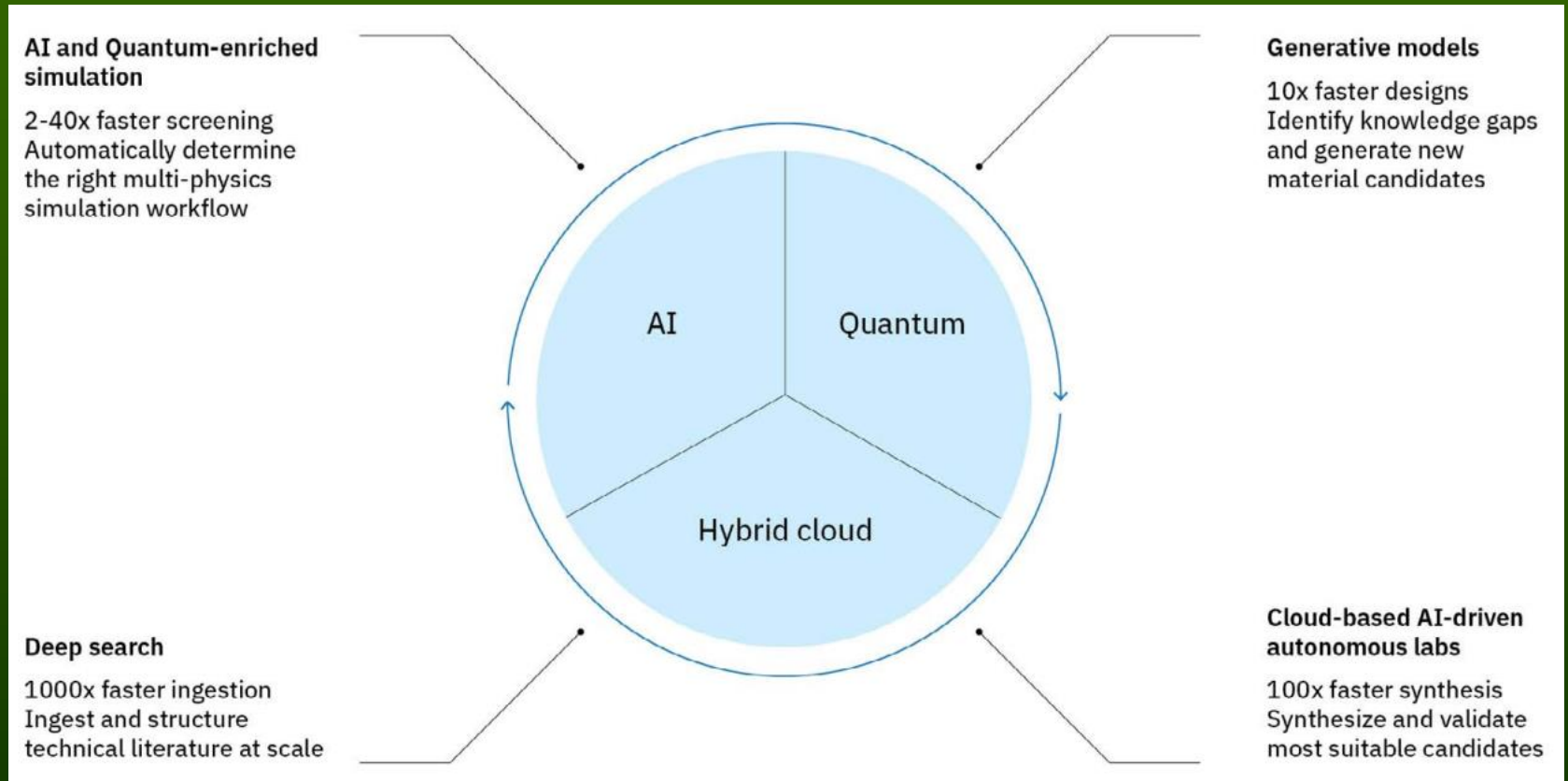

Communities of Discovery are becoming the new paradigm for the practice and advancement of scientific discovery. AI tools support discovery process at every step, from questions to reports. Try [Labworm list](#) of tools.

BERT



Language models may encode knowledge about relation of words in complex network structures. In 2018 Google group created BERT, language model pre-trained on a large text corpus to gain a general-purpose “language understanding”. That model is then fine-tuned for specific NLP tasks such as question answering or semantic information retrieval.

- **Bidirectional Encoder Representations from Transformers (BERT)**.
Transformer-based machine learning technique for (NLP) pre-training.
- English-language BERT: two networks, smaller 110M parameters, and larger model, a 24-layer 340M parameter architecture; trained on the BooksCorpus with 800M words, and Wikipedia with 2,500M words.
- 12/2019 BERT worked in 70 languages, in 2020 many smaller pre-trained models with the whole word masking open software models were published in GitHub repository.
- Masking some words the system learns to predict them, ex:
Input: the man went to the [MASK1] . he bought a [MASK2] of milk.
Labels: [MASK1] = store; [MASK2] = gallon
- Super-human Q/A on Stanford Question Answering Dataset (SQuAD)

State of the art

- Super-human Q/A on [Stanford Question Answering Dataset](#) (SQuAD)

Speech & NLP Technologies are Evolving Quickly

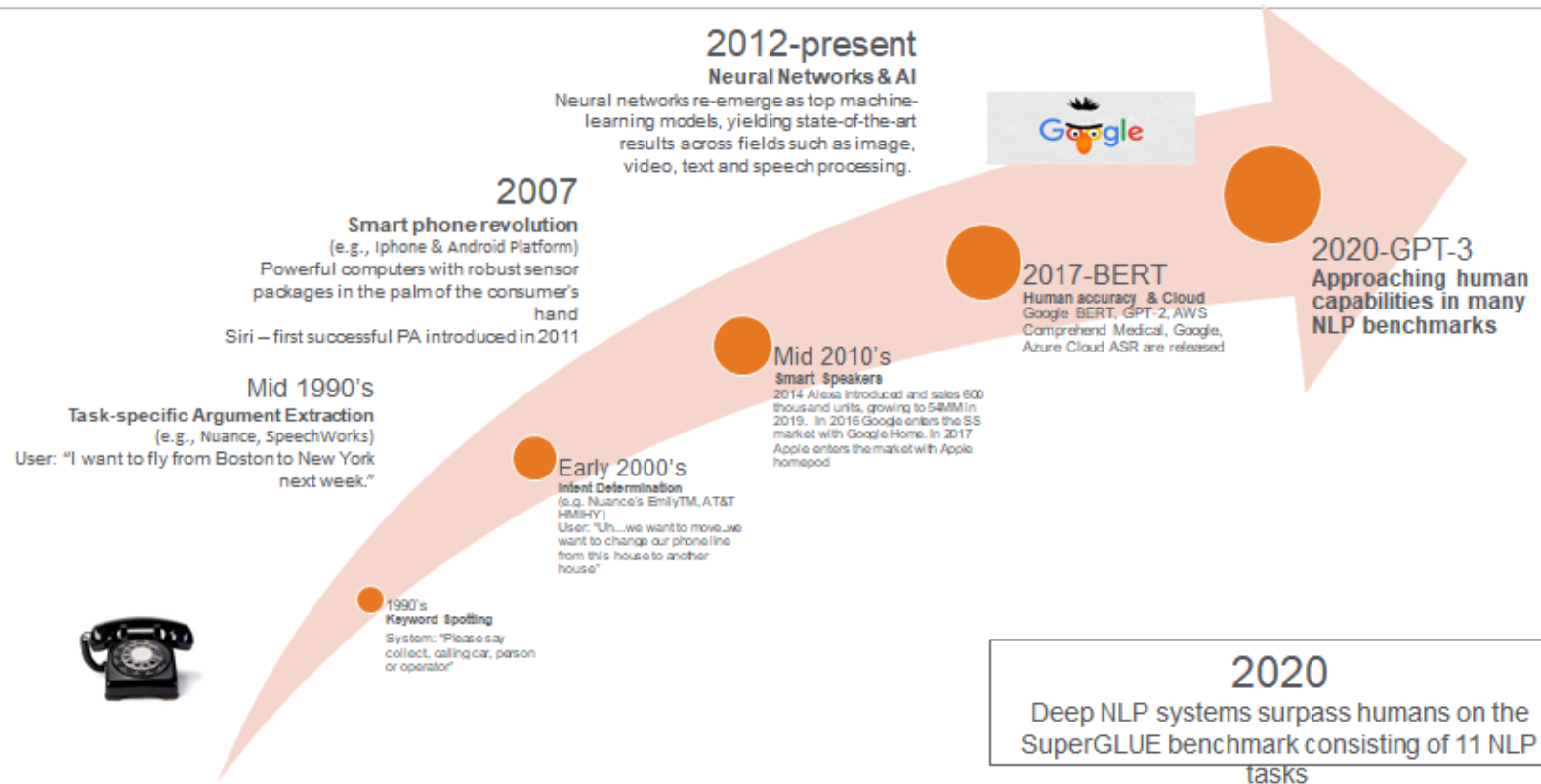

NLP supermodels

OpenAI GPT-3 model ma 175 mld parametrów! Można z nim się pobawić.
First-of-its-kind API can be applied to any language task, and currently serves millions of production requests each day.

Google Switch Transformer ~1.6 trillion parameters

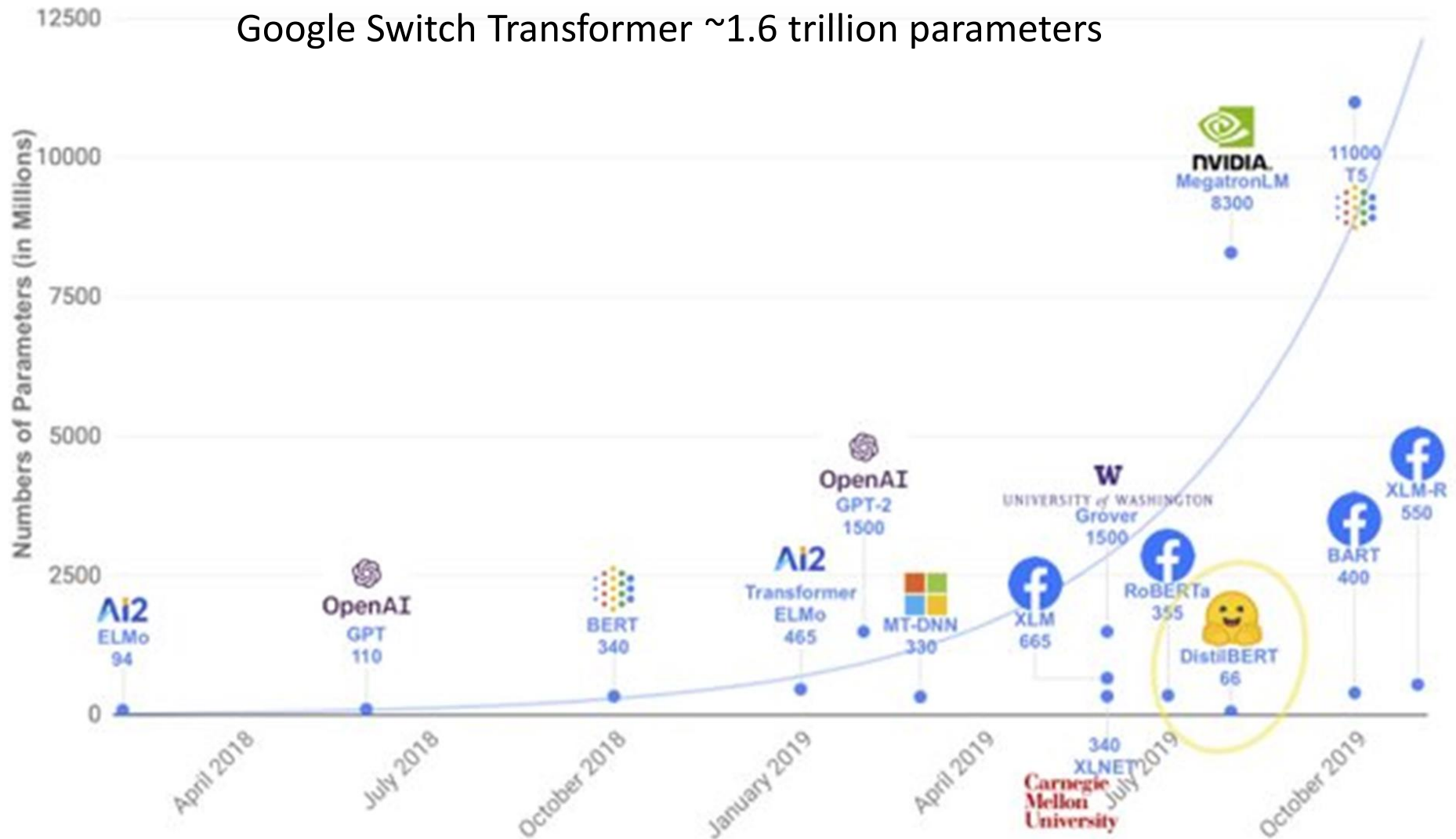

Communities of Discovery

Sharing resources and skills in an open collaborative environment.

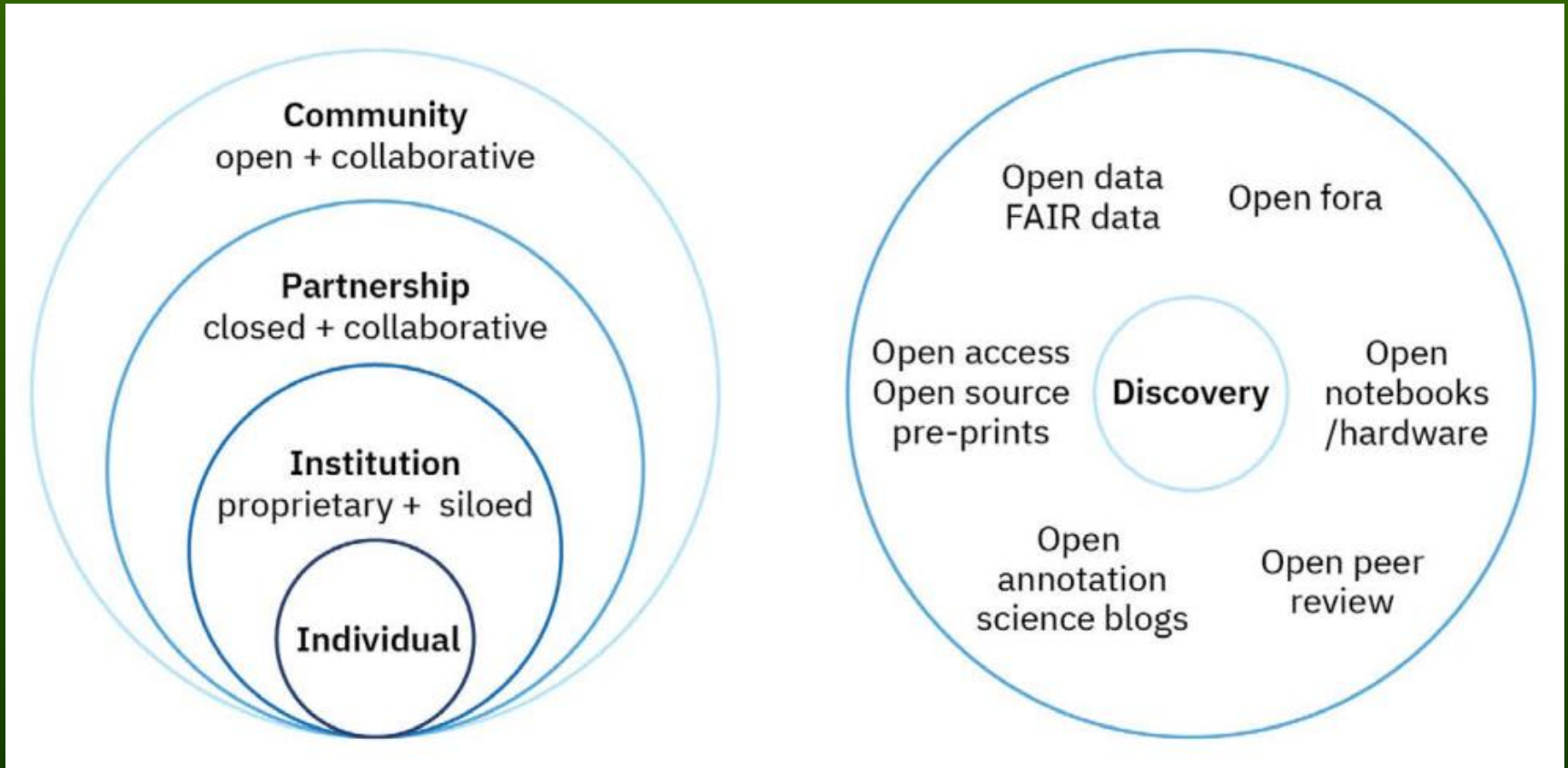

[COVID-19 High Performance Computing](#), huge public-private partnership in molecular medicine, protein interaction, epidemiology, dozens of consortium members from top government, industry, and academia institutions.

[JEDI challenge](#), 54 billion molecules against COVID-19 screened in phase 1 of 3

Serious application

Tshitoyan, V. ... Jain, A. (2019). Unsupervised word embeddings capture latent knowledge from materials science literature. [Nature, 571\(7763\), 95.](#)

Materials science knowledge present in the published literature can be efficiently encoded as information-dense word embeddings without human supervision. Without any explicit insertion of chemical knowledge, these embeddings capture complex materials science concepts such as the underlying structure of the periodic table and structure–property relationships in materials.

An unsupervised method can recommend materials for functional applications several years before their discovery.

GPT Crush: see applications in business, design, education, philosophy, research, creative writing and many other areas.

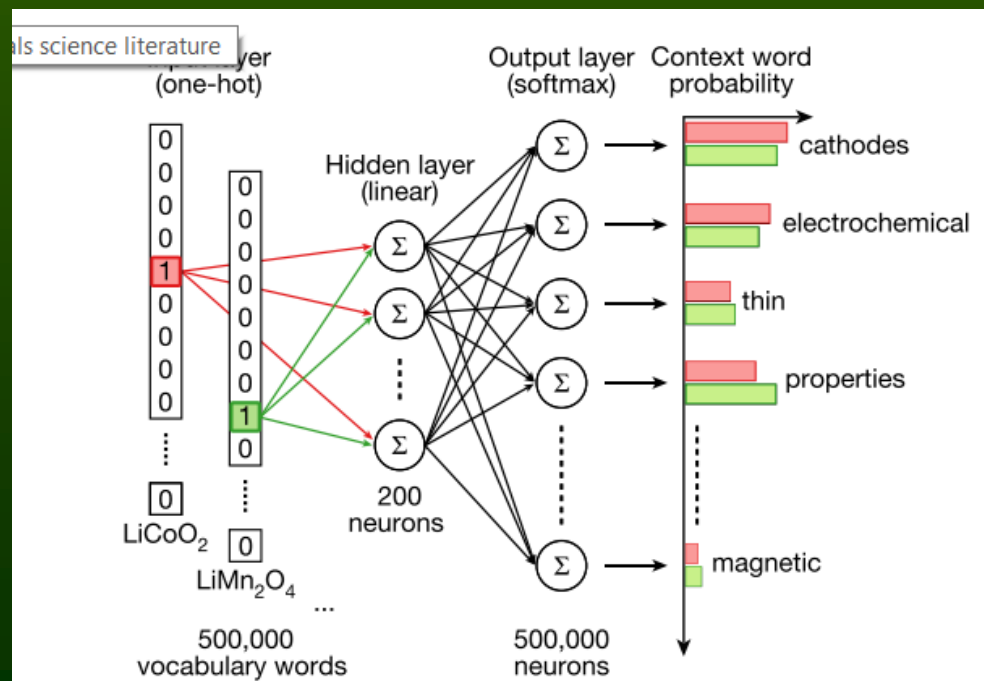

Applications in chemistry/materials

- A. C. Vaucher, F. Zipoli, J. Geluykens, V. H. Nair, P. Schwaller, T. Laino, Automated extraction of chemical synthesis actions from experimental procedures. *Nature Communications*, 2020.
- P. B. Jørgensen, M. N. Schmidt, O. Winther, Deep Generative Models for Molecular Science. *Molecular Informatics*, 2018.
- D. Schwalbe-Koda, R. Gomez-Bombarelli, “Generative Models for Automatic Chemical Design,” arXiv:1907.01632v1 , 2019
- T. Maziarka, A. Pocha, J. Kaczmarek, K. Rataj, T. Danel, M. Warchoł, Mol-CycleGAN: a generative model for molecular optimization, *Journal of Cheminformatics*, 2020.
- C.W. Coley, N.S. Eyke, K.F. Jensen, Autonomous discovery in the chemical sciences part I: Progress, part II: Outlook. *arXiv:2003.13754v1*, 2020.
- E. O. Pyzer-Knapp, T. Laino (eds), “Machine Learning in Chemistry: Data-Driven Algorithms, Learning Systems, and Predictions,” 1326, 2019.
- P. Schwaller, T. Laino, T. Gaudin, P. Bolgar, C. A. Hunter, C. Bekas, A. A. Lee, “Molecular Transformer: A Model for Uncertainty-Calibrated Chemical Reaction Prediction,” *ACS Cent. Sci.*, 5, 1572-1583, 2019.

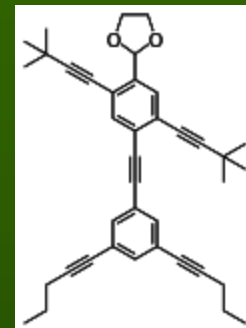

More chemistry/materials

- N. Nosengo, “Can you teach old drugs new tricks?” *Nature*, 534, (2016), 314
- L. Himanen, A. Geurts, A. S. Foster, P. Rinke, Data-Driven Materials Science: Status, Challenges, and Perspectives. *Advanced Science*, 2019.
- D. C. Elton, Z. Boukouvalas, M. D. Fuge, P. W. Chung, “Deep learning for molecular design—a review of the state of the art,” *arXiv:1903.04388v3*, [cs. LG], 2019.
- P. Staar, M. Dolfi, C. Auer. Corpus Processing Service: A Knowledge Graph Platform to perform deep data exploration on corpora. *Authorea* 2020.
- S. Takeda, et al, Molecular Inverse-Design Platform for Material Industries. *Proc. ACM KDD-2020*.
- Ł. Maziarka, T. Danel, S. Mucha, K. Rataj, J. Tabor, S. Jastrzebski. Molecule Attention Transformer. *arXiv:2002.08264v1* [cs.LG], 2020.

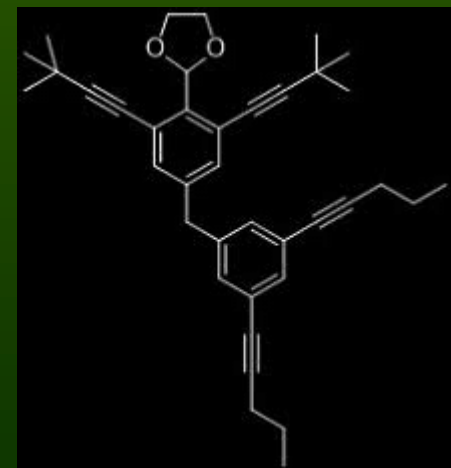

Duch W and Diercksen GHF (1994) [Neural networks as tools to solve problems in physics and chemistry](#). CPC 82, 91-103.

Brains and minds

Geometric model of mind

Brain \leftrightarrow Psyche

Objective \leftrightarrow Subjective

Neurodynamics: bioelectrical activity of the brain, neural activity measured using EEG, MEG, NIRS-OT, PET, fMRI, other techniques.

Mapping $S(M) \leftrightarrow S(B)$ but how to describe the state of mind? **Brain fingerprints?**

Verbal description is not sufficient.

A space with dimensions that measure different aspects of experience is needed.

Mental states, movement of thoughts \leftrightarrow trajectories in psychological spaces.

Problem: good phenomenology. We are not able to describe our mental states.

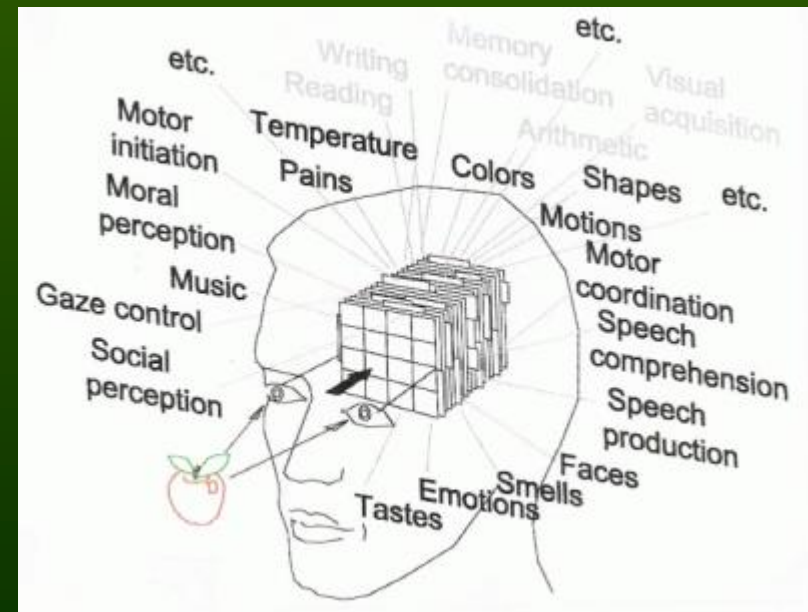
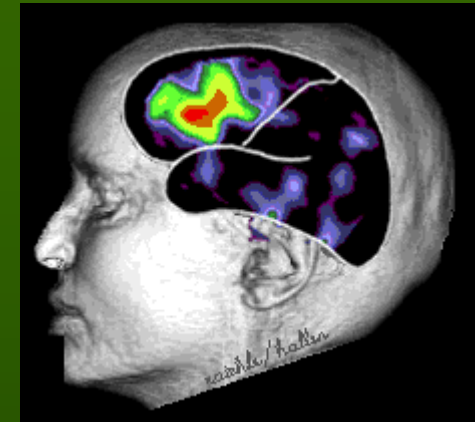

Hurlburt & Schwitzgabel, Describing Inner Experience? MIT Press 2007

Mental state: strong coherent activation

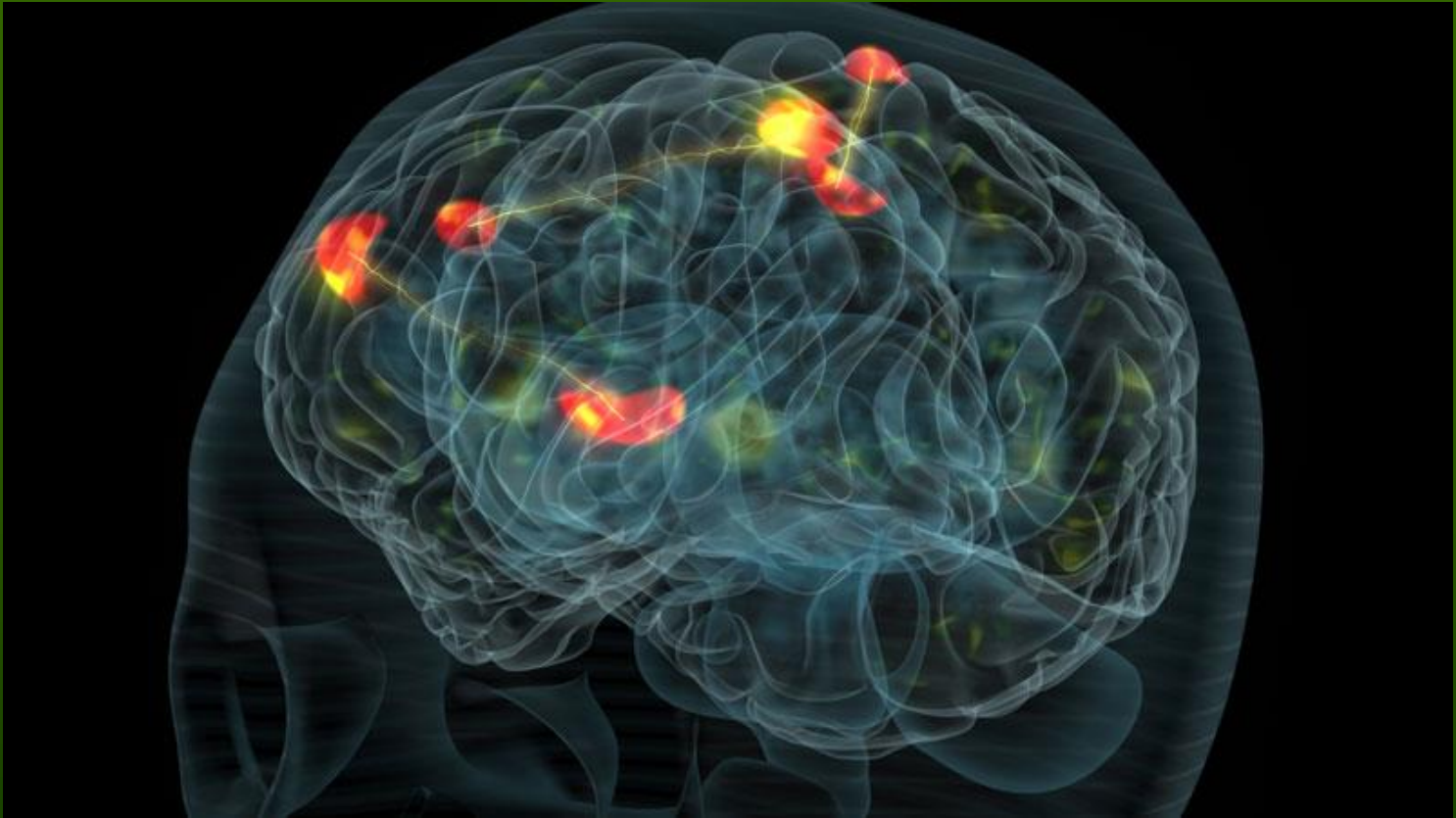

Many processes go on in parallel, controlling homeostasis and behavior. Most are automatic, hidden from our Self. What goes on in my head? Various subnetworks compete for access to the highest level of control - consciousness, the winner-takes-most mechanism leaves only the strongest. How to extract stable intentions from such chaos? BCI is never easy.

On the threshold of a dream ...

Final goal: optimize brain processes!

Although whole brain is always active we are far from achieving full human potential. To repair damaged brains and increase efficiency of healthy brains we need to understand brain processes:

1. Find **fingerprints of specific activity** of brain structures (regions, networks) using neuroimaging technology (and new neurotechnologies).
2. Create **models of cognitive architectures** that help to understand information processing in the brain.
3. Create **new diagnostic and therapeutic procedures**.
4. Use **neurofeedback based on decoding and changes in connectivity** and close-loop system that directly **stimulate the brain**.

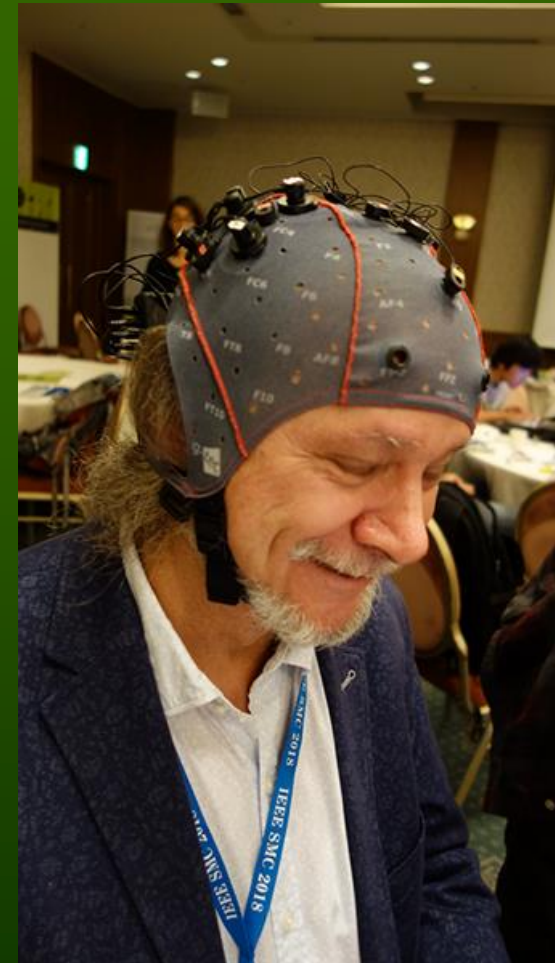

G-tec wireless NIRS/EEG on my head.

Duch W, *Brains and Education: Towards Neurocognitive Phenomics*. 2013

BCI: wire your brain ...

Non-invasive, partially invasive and invasive signals carry progressively more information, but are also harder to implement. EEG is still the king!

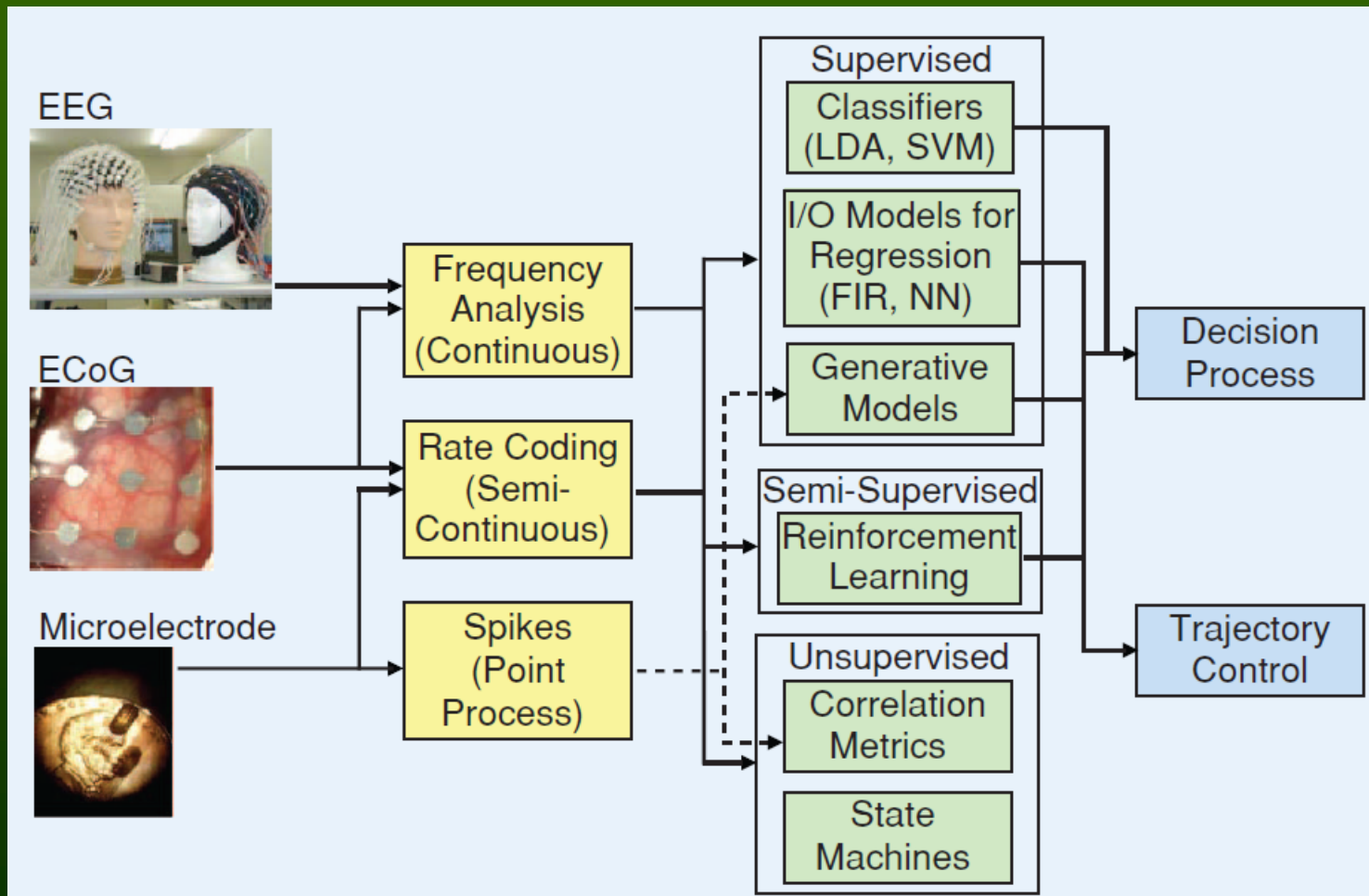

Brain activity \leftrightarrow Mental image

fMRI activity can be correlated with deep CNN network features; using these features closest image from large database is selected. Horikawa, Kamitani, Generic decoding of seen and imagined objects using hierarchical visual features. Nature Comm. 2017.

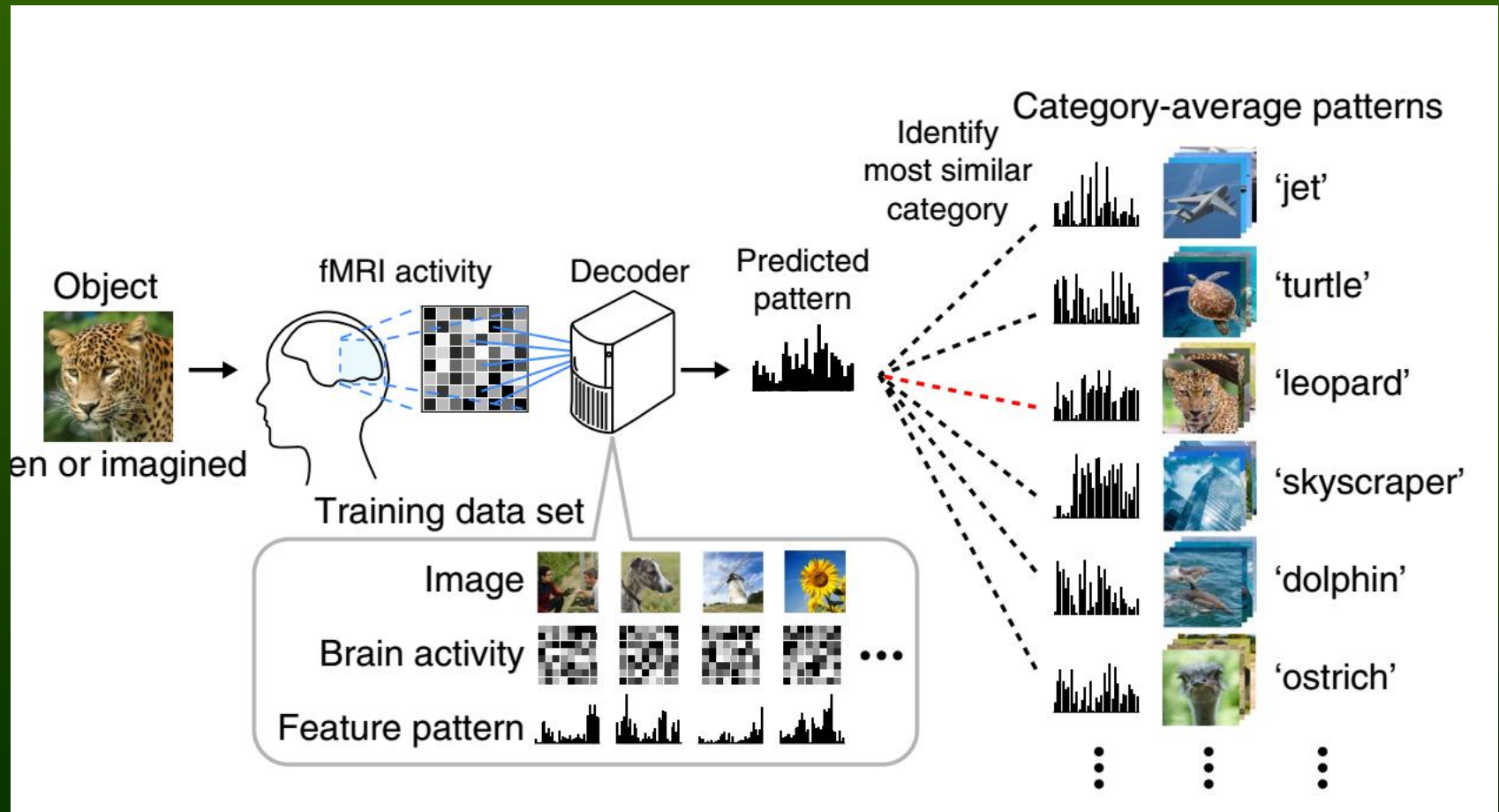

Decoding Dreams



Decoding Dreams, ATR Kyoto, Kamitani Lab. fMRI images analysed during REM phase or while falling asleep allows for dream categorization (~20 categories).

Dreams, thoughts ... can one hide what has been seen and experienced?

Neuroscience => AI



Hassabis, D., Kumaran, D., Summerfield, C., Botvinick, M. (2017). **Neuroscience-Inspired Artificial Intelligence**. *Neuron*, 95(2), 245–258.

Affiliations: **Google DeepMind**, Gatsby, ICN, UCL, Oxford.

Bengio, Y. (2017). The **Consciousness Prior**. *ArXiv:1709.08568*.

Amos et al. (2018). **Learning Awareness Models**. ICRL, *ArXiv:1804.06318*.

AI Systems inspired by Neural Models of Behavior:

- (A) **Visual attention** foveal locations for multiresolution “retinal” representation, prediction of next location to attend to.
- (B) **Complementary learning systems** and episodic control: fast learning hippocampal system and parametric slow-learning neocortical system.
- (C) Models of **working memory** and the Neural Turing Machine.
- (D) Neurobiological models of **synaptic consolidation**

SANO new Centre for Individualized Computational Medicine in Kraków (EU Team project, with Sheffield Uni, Fraunhofer Society, Research Centre Juelich).

Neural screen

Features are discovered, and their combination remembered as face, but precise recognition needs detailed recording from neurons – only 205 neurons in a few visual areas used.

L. Chang and D.Y. Tsao, “The code for facial identity in the primate brain” *Cell* 2017

1. We recorded responses to parameterized faces from macaque face patches

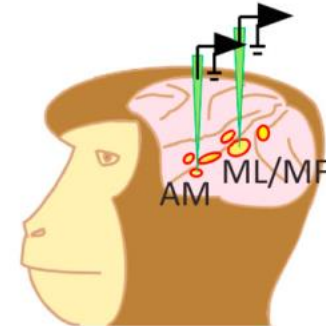

2. We found that single cells are tuned to single face axes, and are blind to changes orthogonal to this axis

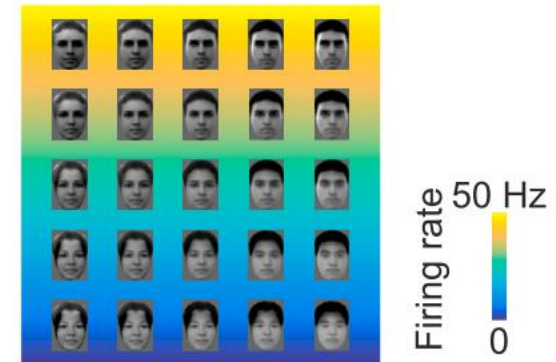
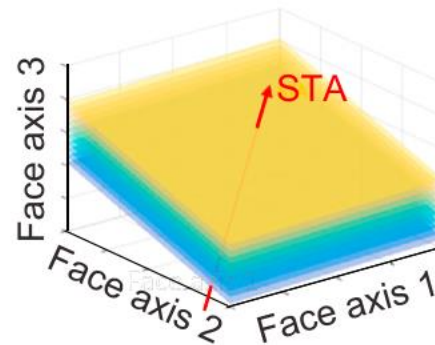

3. We found that an axis model allows precise encoding and decoding of neural responses

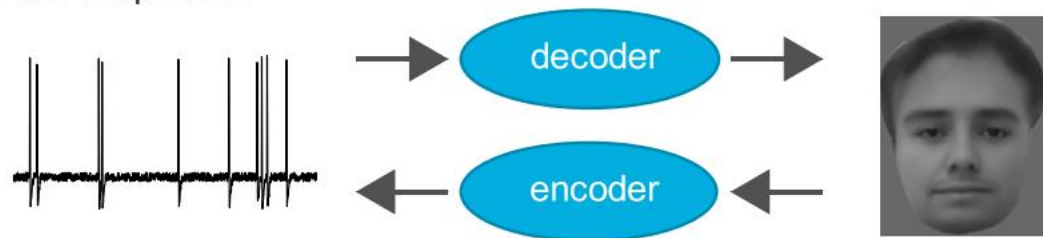

Mental images

Facial identity is encoded via a **simple neural code** that relies on the ability of neurons to distinguish facial features along **specific axes in the face space**.

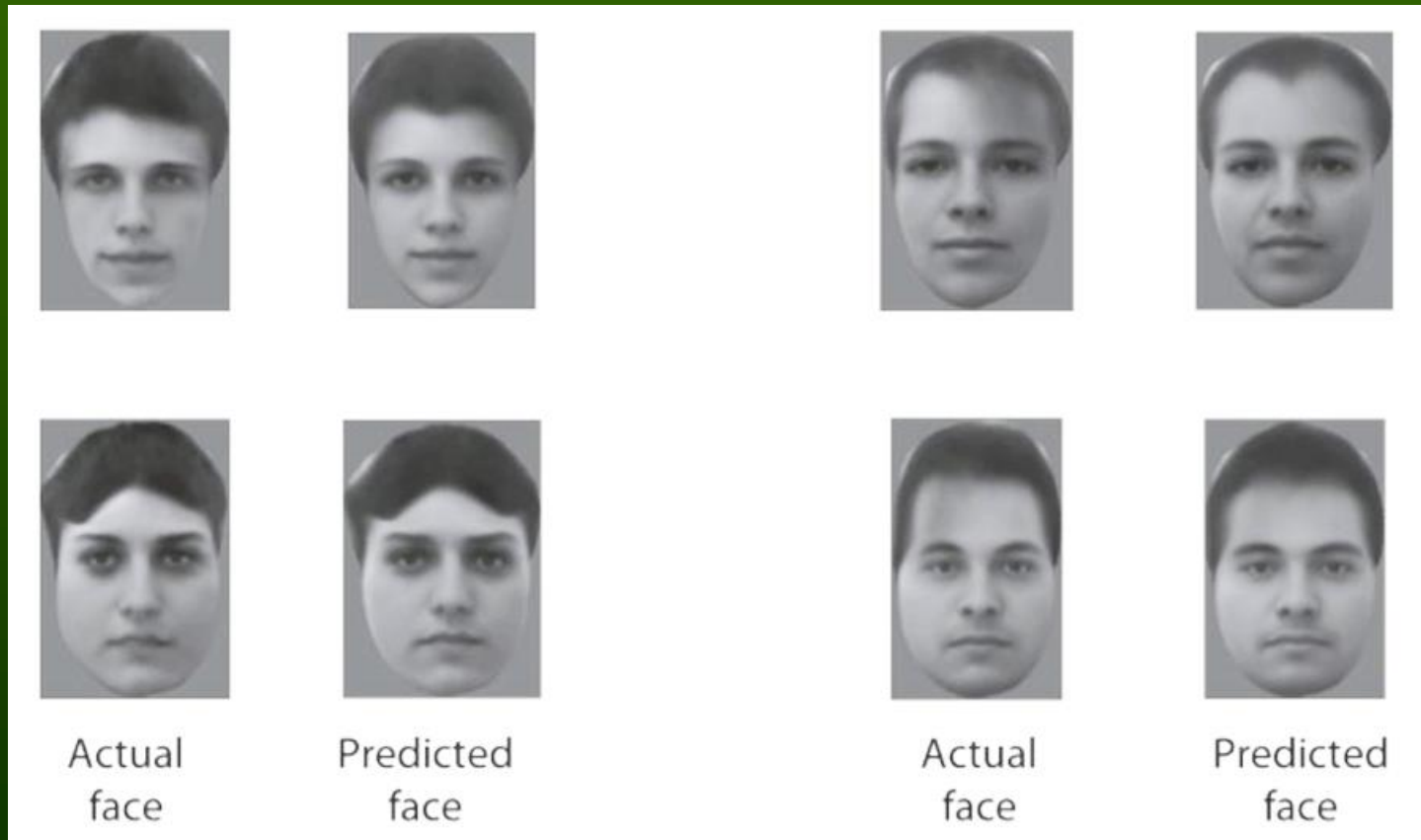

AI=>Neuroscience



ML techniques are basic tools for analysis of neuroimaging data.

Ideas from animal psychology helped to give birth to reinforcement learning (RL) research. Now **key concepts from RL inform neuroscience**.

Activity of midbrain dopaminergic neurons in conditioning paradigms has a striking resemblance to temporal difference (TD) generated prediction errors - **brain implements a form of TD learning!**

CNN \Leftrightarrow interpret neural representations in high-level ventral visual stream of humans and monkeys, finding evidence for deep supervised networks.

LSTM architecture provides key insights for development of working memory, gating-based maintenance of task-relevant information in the prefrontal cortex.

Backpropagation with symmetric feedback and feedforward connectivity is not realistic, but **random backward connections** allow the backpropagation algorithm to function effectively through a process whereby adjustment of the forward weights allows backward projections to transmit useful teaching signals.

Functional brain networks

~ Small worlds architecture



Physiological Reviews © 2020



All complex functions are based on synchronization of many distributed brain areas. Memory, personality or consciousness are collection of functions, like multi-agent systems or the “society of mind”. Psychological constructs should be “deconstructed” to connect them with specific brain processes.

Neurocognitive Basis of Cognitive Control

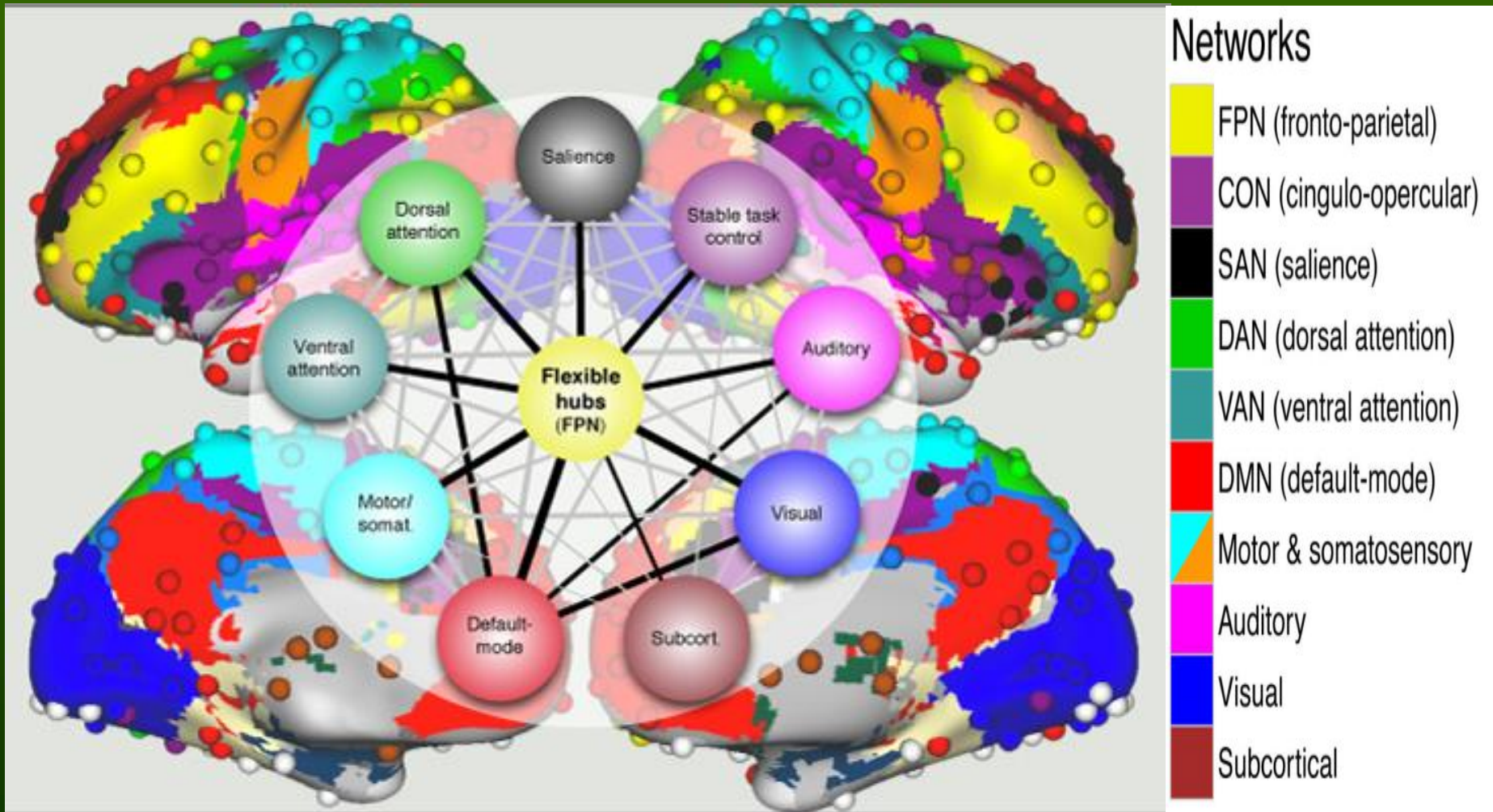

Central role of fronto-parietal (FPN) flexible hubs in cognitive control and adaptive implementation of task demands (black lines=correlations significantly above network average). Cole et al. (2013).

Pathological functional connections

Comparison of connections for patients with ASD (autism spectrum), TSC (Tuberous Scelrosis), and ASD+TSC.

Weak or missing connections between distant regions prevent ASD/TSC patients from solving more demanding cognitive tasks.

Network analysis becomes very useful for diagnosis of changes due to the disease and learning.

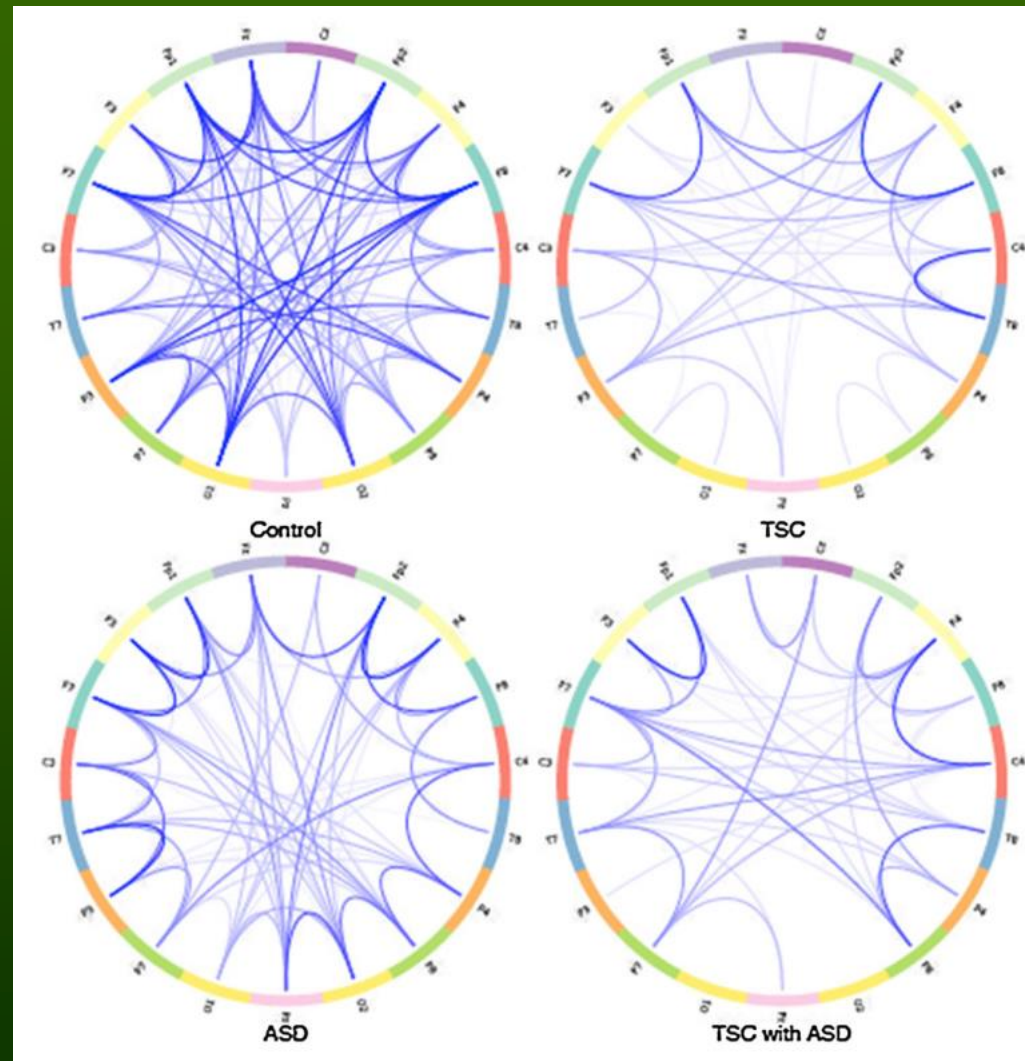

J.F. Glazebrook, R. Wallace, Pathologies in functional connectivity, feedback control and robustness. *Cogn Process* (2015) 16:1–16

Rozwój inteligencji

W okresie niemowlęcym najpierw ruch i związane z nim wrażenia wpływają na organizację przepływu informacji przez mózg. Zanim dziecko zacznie wymawiać słowa pokazuje swoje intencje gestami (nauka .

The Developing Human Connectome Project: jak rozwija się konektom, sieć połączeń w mózgu w okresie pre-natalnym, 20 - 44 tygodnia ciąży? Badania za pomocą neuroobrazowania (fMRI, EEG), obserwacji ruchów i reakcji płodu, genetyce. Neurony wysyłają impulsy dopiero w 24 tyg. ciąży.

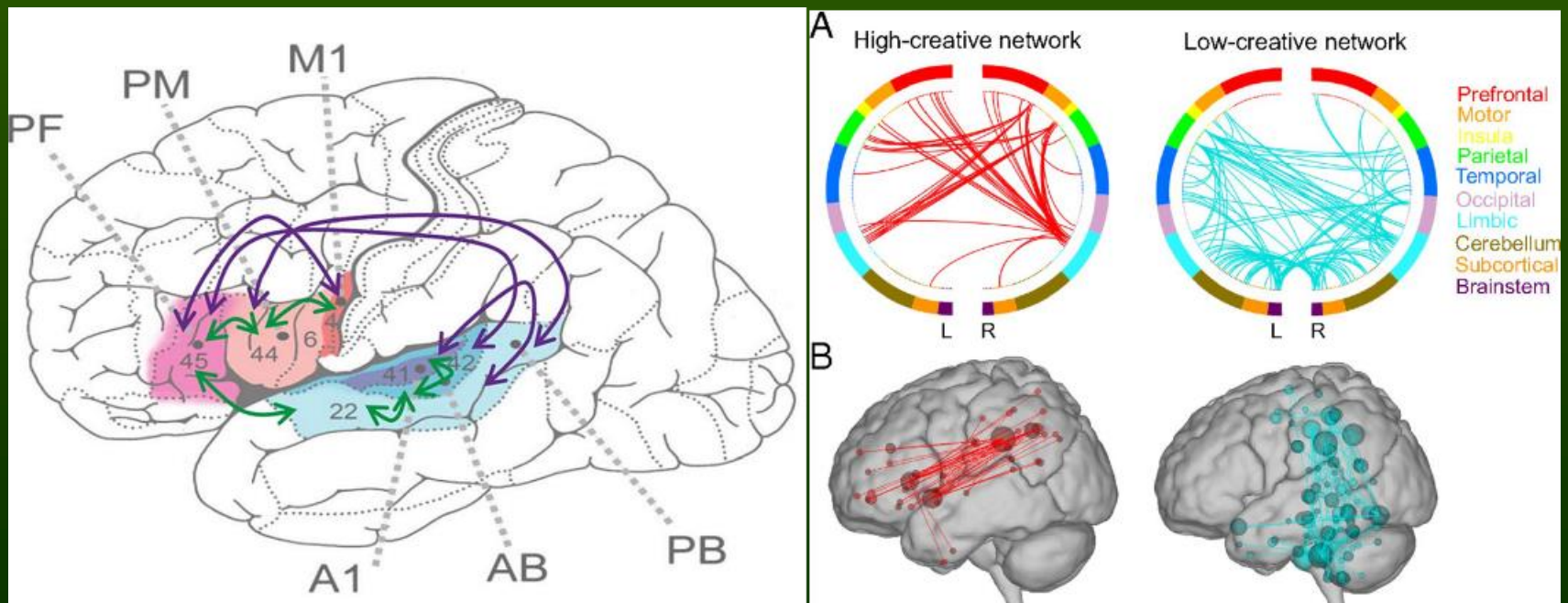

Effect of cognitive load

Simple and more difficult tasks, requiring the whole-brain network reorganization.

Left: 1-back Top: connector hubs

Right: 2-back Bottom: local hubs

Average over 35 *participants*.

Dynamical change of the landscape of attractors, depending on the cognitive load. DMN areas engaged in global binding!

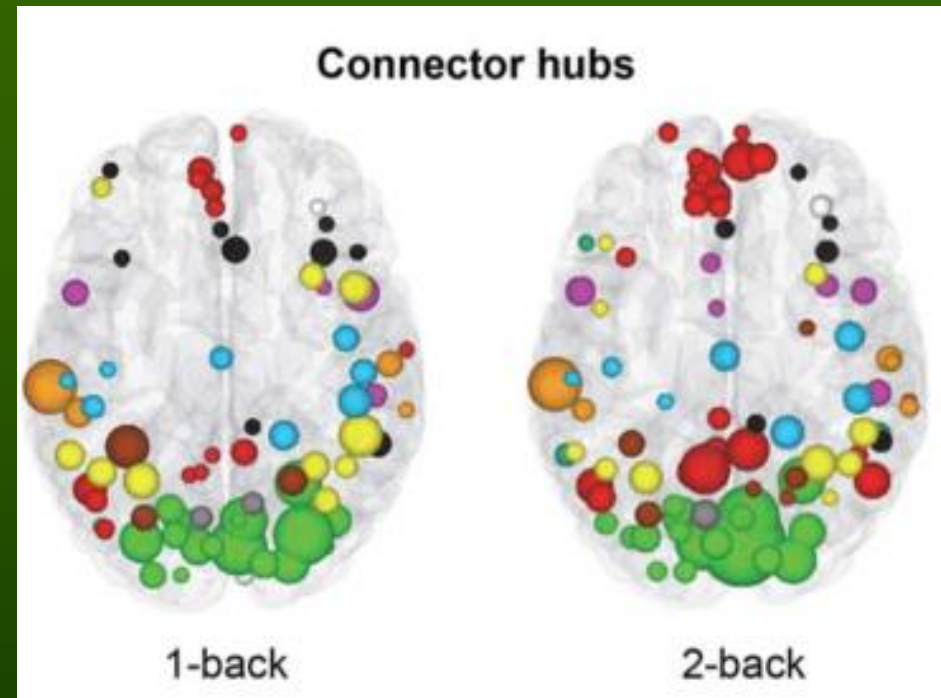

K. Finc et al, HBM (2017).

Working memory training

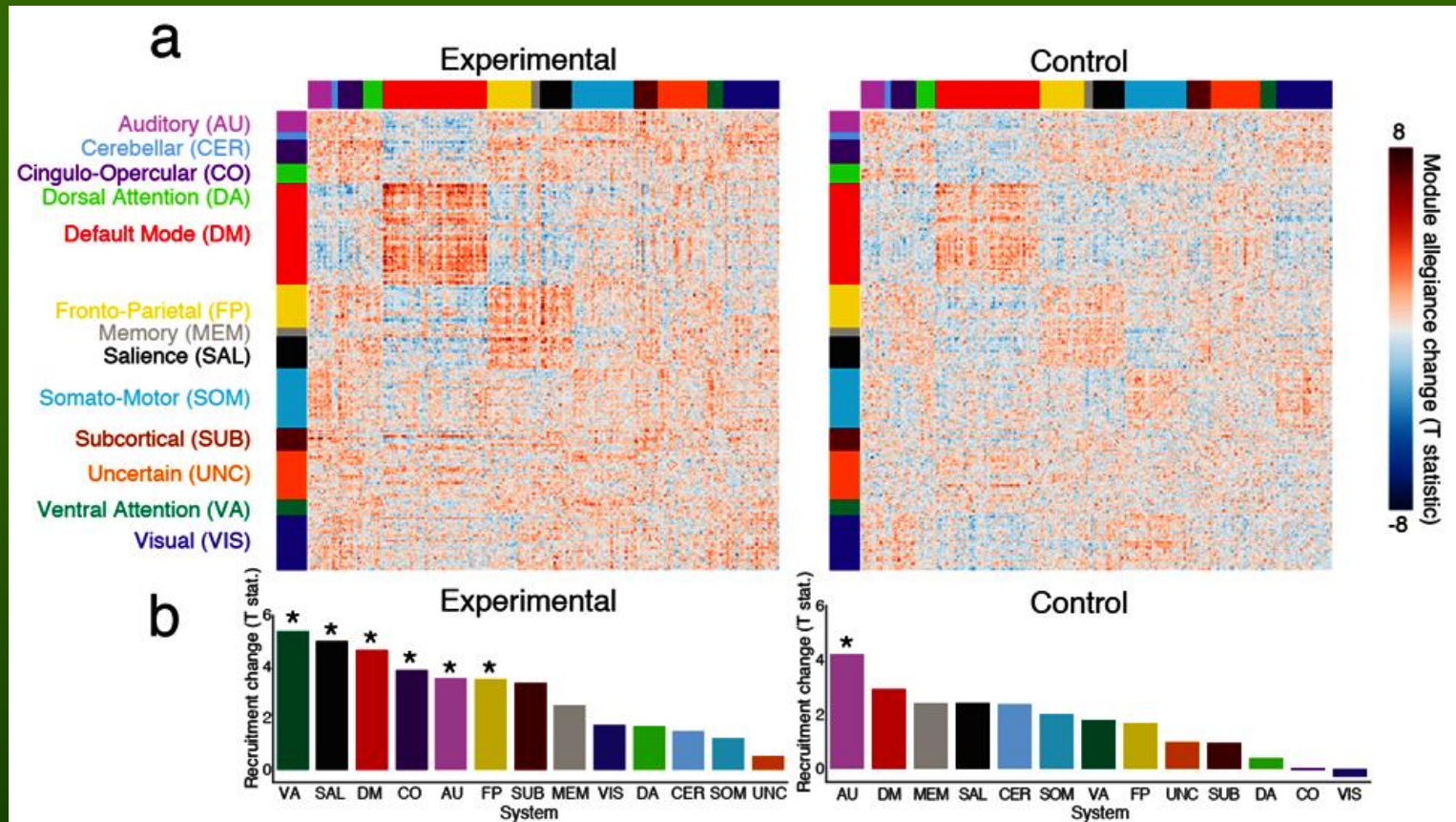

Whole-brain changes in module allegiance between the 'Naive' and 'Late' 6-week working memory training stages.

(a) Changes in node allegiance as reflected in the two-tailed *t*-test.

(b) Significant increase * in the default mode, fronto-parietal ventral attention, salience, cingulo-opercular, and auditory systems recruitment.

K. Finc et al, Nature Communications (2020).

Brain activity beyond visual cortex: Gallant Lab

Category zebra: Passive Viewing

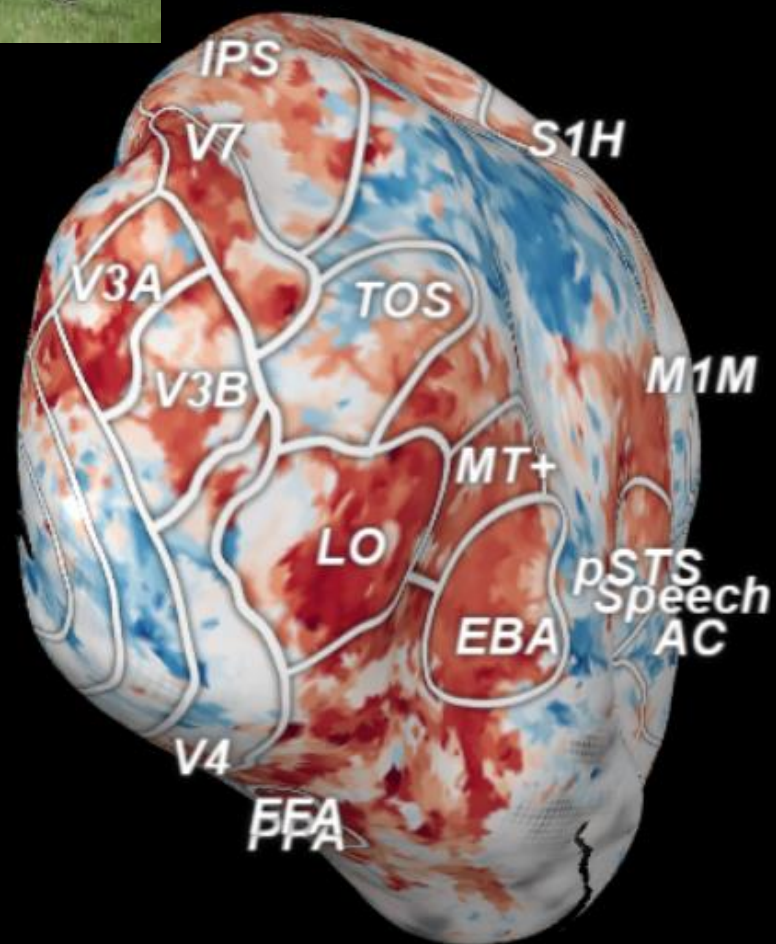
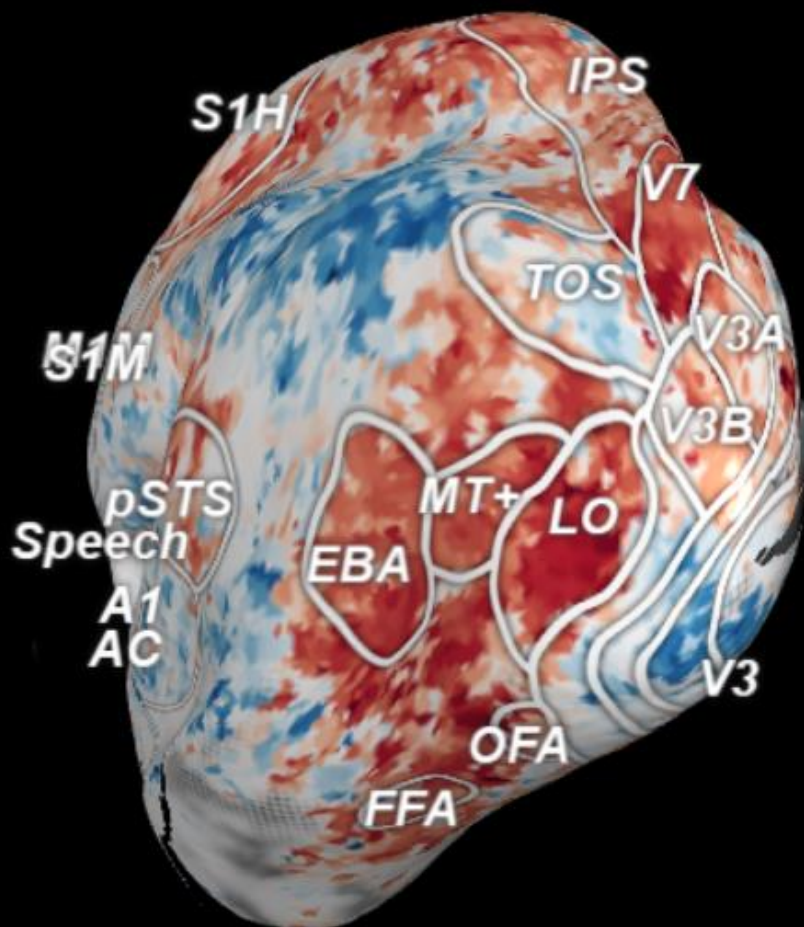

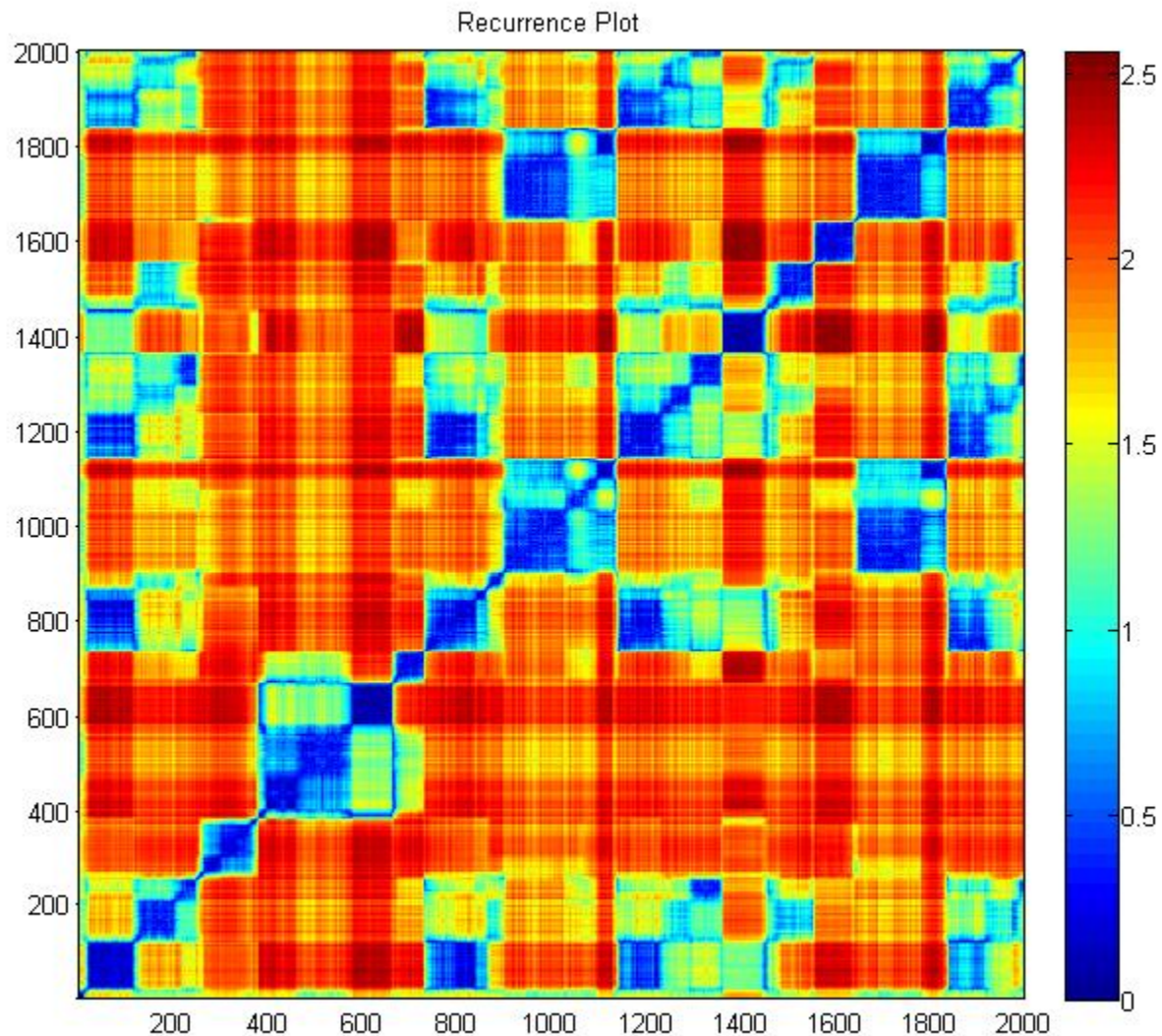

Activation of 140 semantic layer units starting from the word „gain”: rapid transitions between a sequence of related concepts is seen. **Real EEG is coming.**

Rzeczywiste sygnały EEG

Electrode: F5, theta band, embedding = 4, time delay = 25

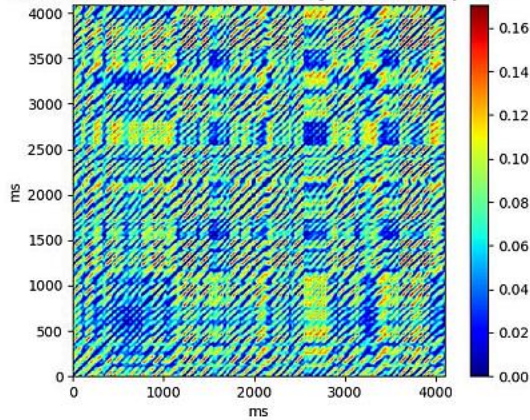

Electrode: F6, theta band, embedding = 4, time delay = 25

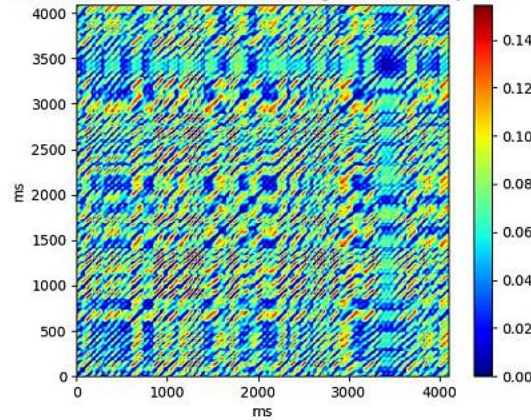

Electrode: C6, theta band, embedding = 5, time delay = 25

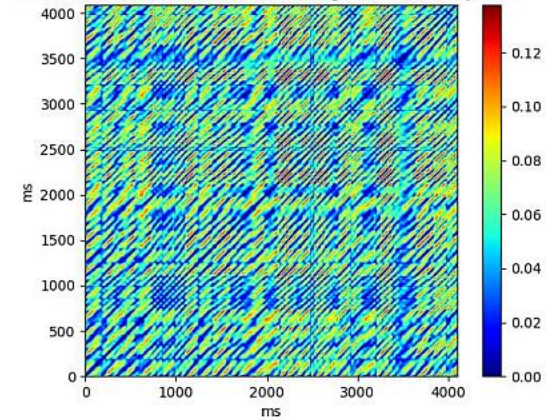

Electrode: C5, theta band, embedding = 4, time delay = 24

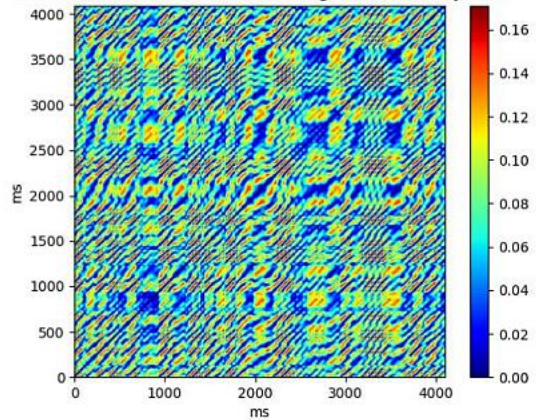

Electrode: Fz, theta band, embedding = 4, time delay = 25

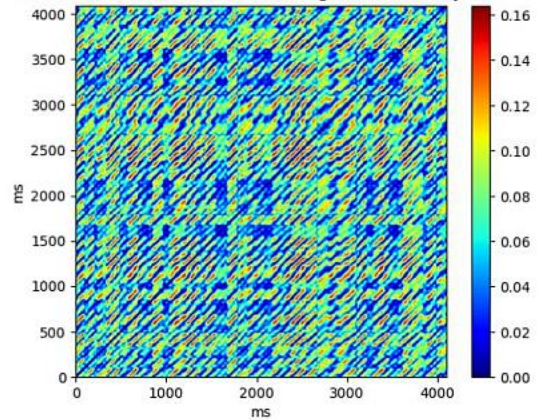

Electrode: Cz, theta band, embedding = 4, time delay = 24

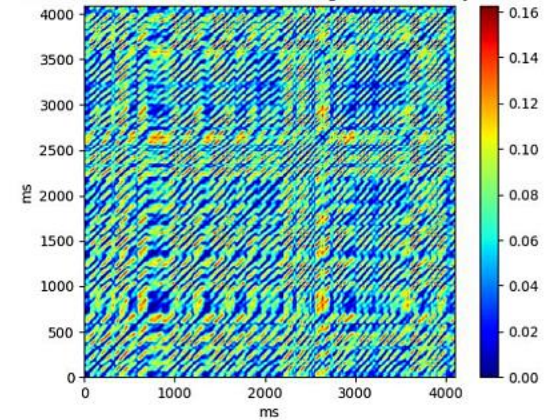

Dane z EEG, 6 kanałów, pasmo teta, rekonstrukcja atraktorów przez embedding:
 $[y(t), y(t-\tau), y(t-2\tau), \dots, y(t-2n\tau)]$

The Virtual Brain (TVB) and its neural population models

Not in TVB

Cellular models

Hodgkin-Huxley

Morris-Lécar

In TVB

Local Field Potential,
synaptic activity

Stefanescu-Jirsa 2D

Stefanescu-Jirsa 3D

Wong-Wang

Firing rate

Wilson-Cowan

Brunel-Wang

Jansen-Rit

All models can be described by
nonlinear dynamic systems via
differential equations

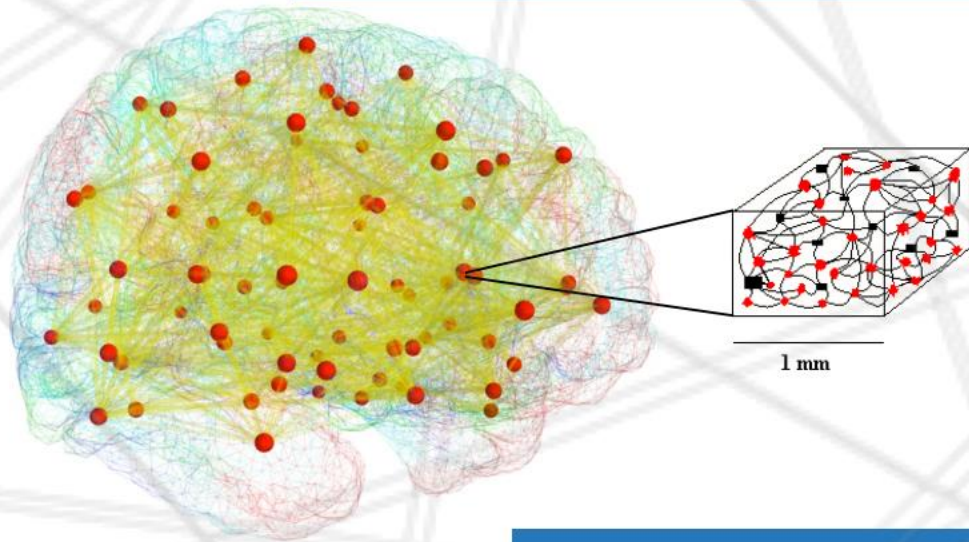

Phenomenological

Generic 2D

Kuramoto

Epileptor

Neurofeedback may repair network?

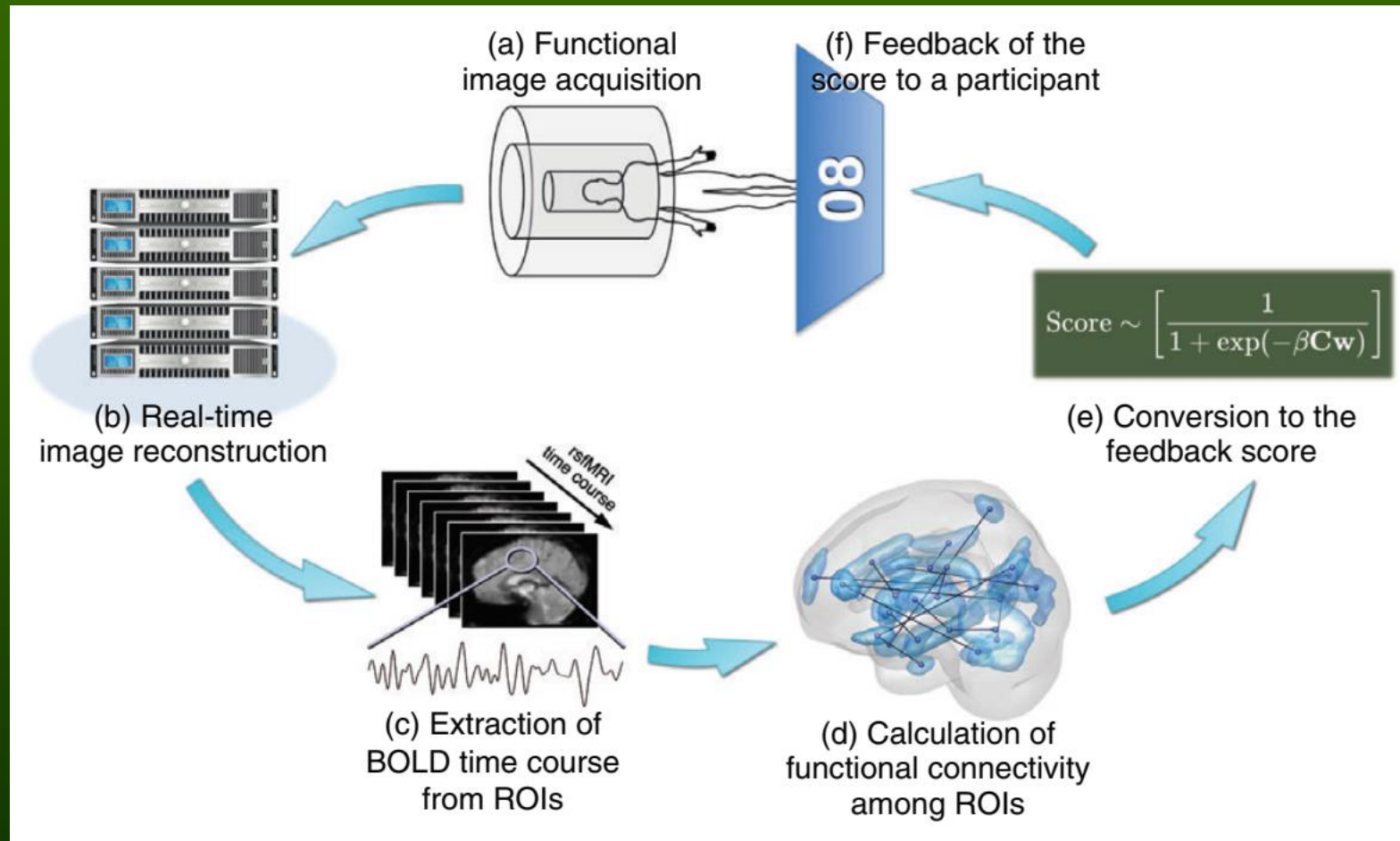

Megumi F, Yamashita A, Kawato M, Imamizu H. Functional MRI neurofeedback training on connectivity between two regions induces long-lasting changes in intrinsic functional network. *Front. Hum. Neurosci.* 2015; 9: 160.

Biomarkers from neuroimaging

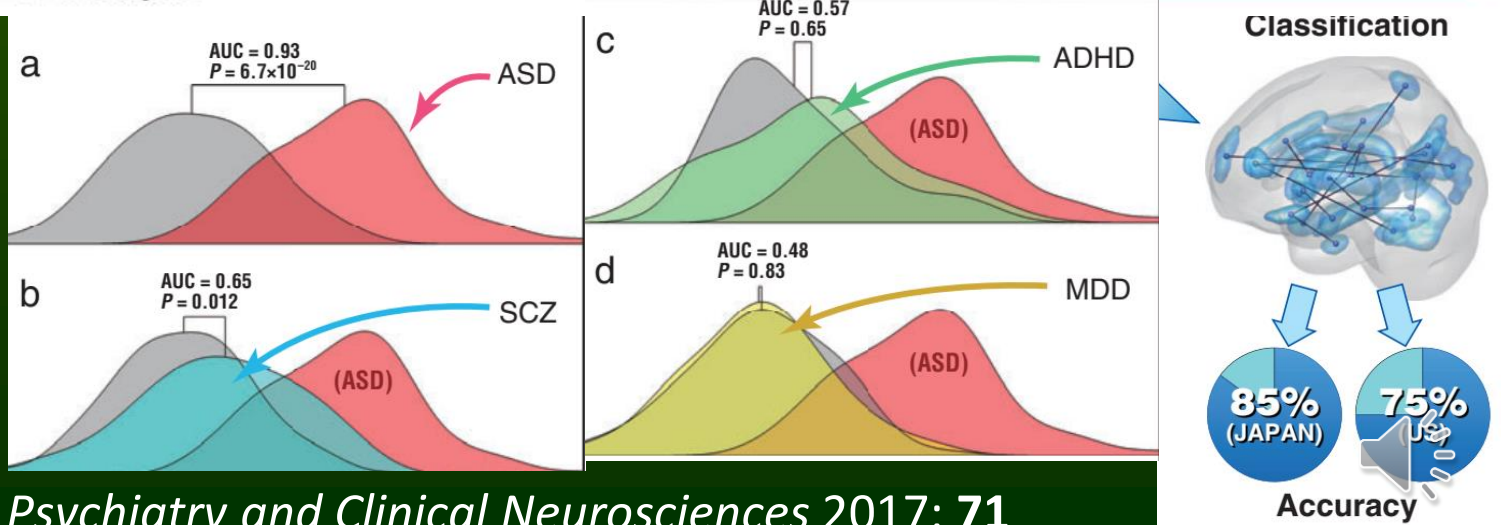
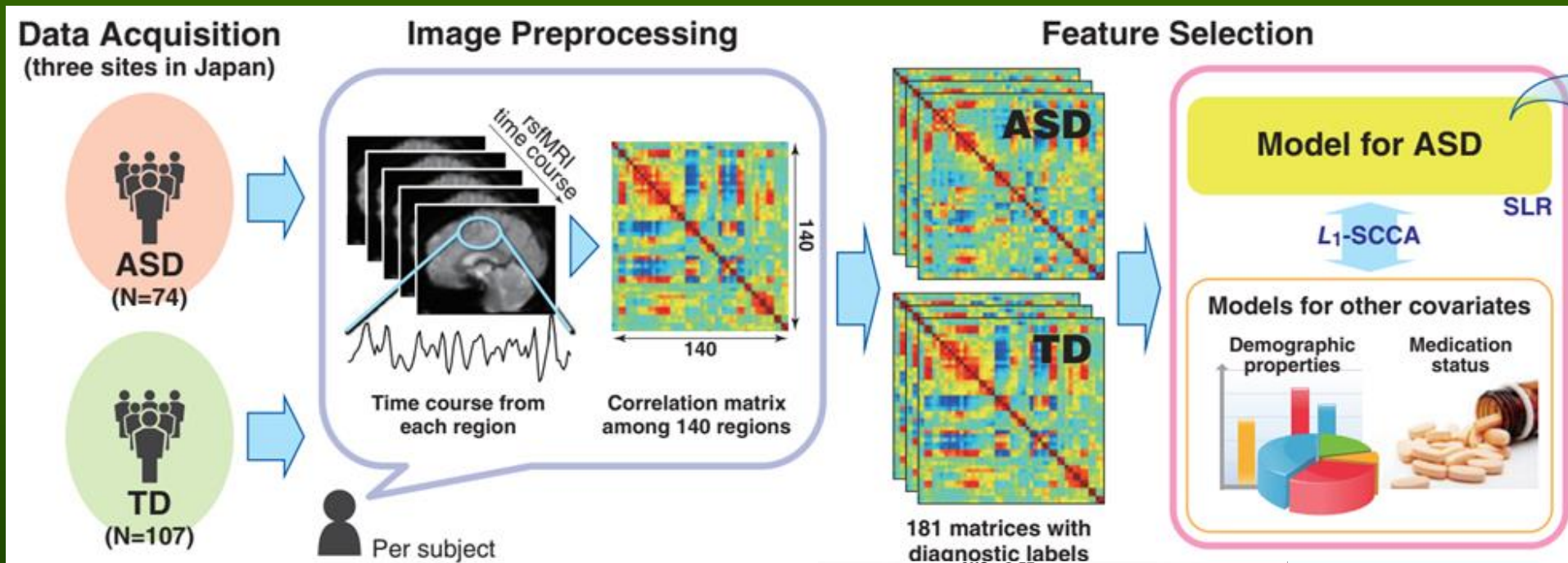

EEG localization and reconstruction

ECD

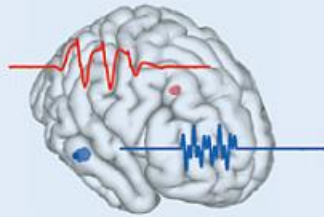

$$\hat{d}_j = \operatorname{argmin} \left\| \phi - \sum_j \mathcal{K}_j d_j \right\|_F^2$$

Rotating dipole

- Moving
- Rotating
- Fixed

Dipole model



Distributed model

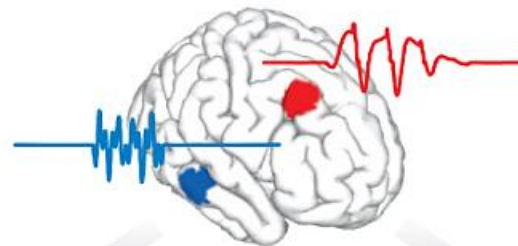

MN (ℓ_2) family

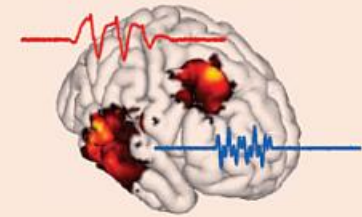

$$\hat{j} = \operatorname{argmin}_j \left\| \phi - \mathcal{K}j \right\|_2^2 + \lambda \left\| j \right\|_2^2$$

$$\hat{j} = \mathcal{T}\phi = \mathcal{K}^\top (\mathcal{K}\mathcal{K}^\top + \lambda I)^{-1} \phi$$

MN

- MN
- WMN
- LORETA

He et al. Rev. Biomed Eng (2018)

Sparse and Bayesian framework

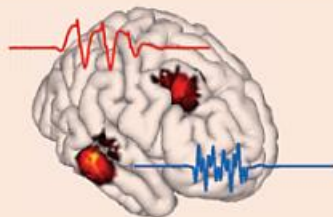

$$\hat{j} = \operatorname{argmin}_j \left\| \mathcal{V}j \right\|_1 + \alpha \left\| j \right\|_1$$

$$\text{S.T. } \left\| \phi - \mathcal{K}j \right\|_{\Sigma^{-1}}^2 \leq \epsilon^2$$

IRES

Beamforming and scanning algorithms

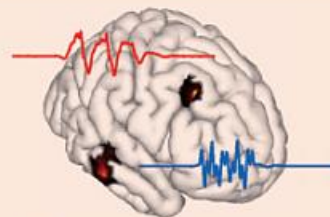

$$\hat{w}_r = \operatorname{argmin}_{w_r} w_r^\top \mathcal{R}_\phi w_r$$

$$\text{S.T. } \begin{cases} \mathcal{K}_r^\top w_r = \xi_1 \\ w_r^\top w_r = 1 \end{cases}; \hat{j} = w^\top \phi$$

Beamformer (VBB)

Nonlinear post hoc normalization

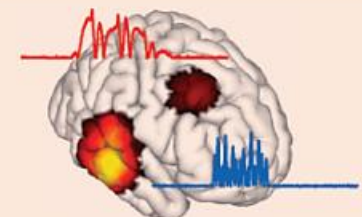

$$\hat{j}_{mn} = \mathcal{T}_{mn}\phi$$

$$S_j = \mathcal{K}^\top (\mathcal{K}\mathcal{K}^\top + \alpha I)^{-1} \mathcal{K}$$

$$\hat{j}_{sl} = \hat{j}_{mn}(\ell)^\top \left([S_j]_{\ell\ell} \right)^{-1} \hat{j}_{mn}(\ell)$$

sLORETA



Memory implants

Ted Berger (USC, [Kernel](#)): hippocampal neural prosthetics facilitate human memory encoding and recall using the patient's own hippocampal spatiotemporal neural codes. Tests on rats, monkeys and on people gave memory improvements on about 35% ([J. Neural Engineering 15, 2018](#)).

DARPA: Restoring Active Memory (RAM), new closed-loop, non-invasive systems that leverage the role of neural “replay” in the formation and recall of memory to help remember specific episodic events and learned skills.

RNS for epilepsy!

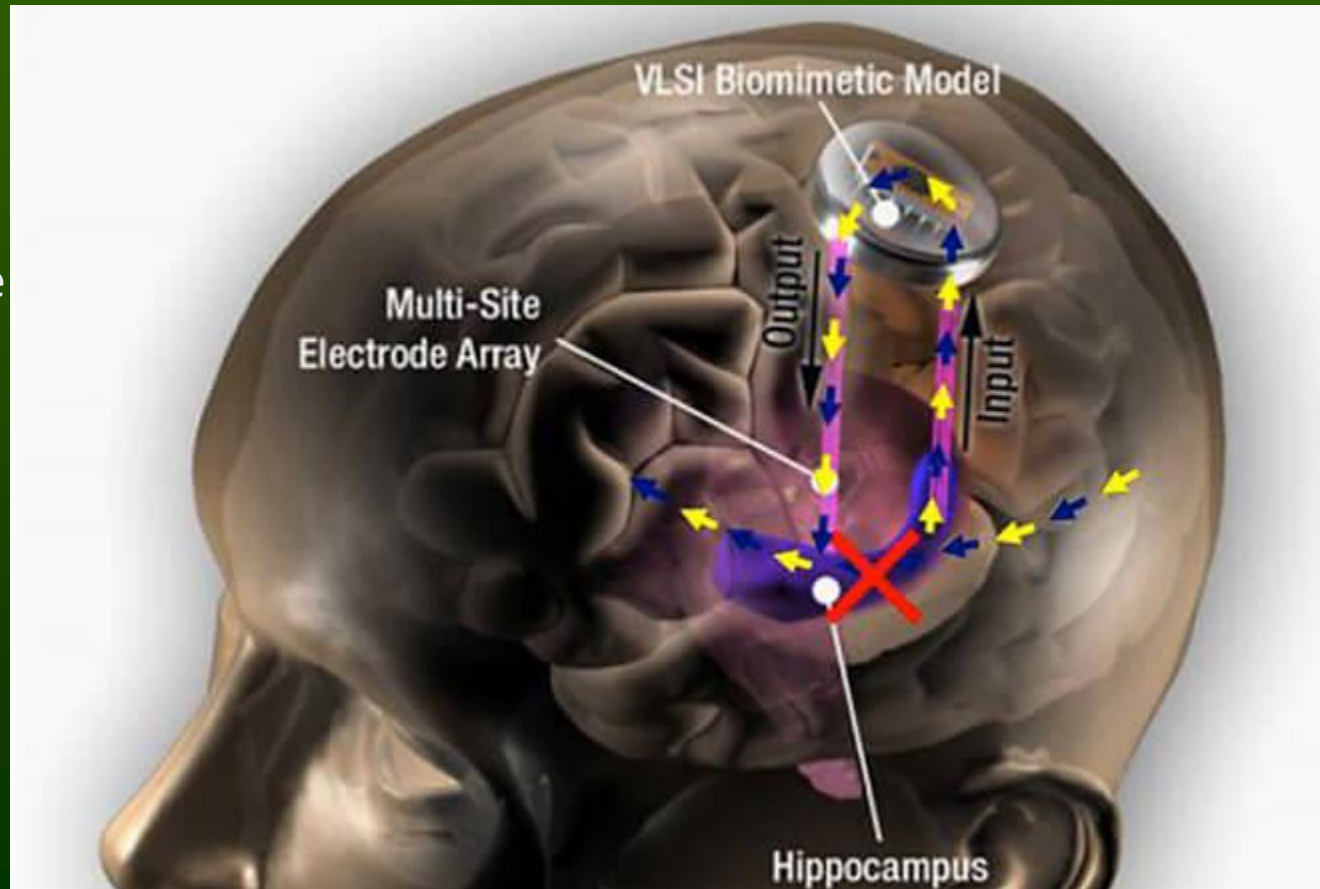

Million nanowires in your brain?

DARPA (2016): **Neural Engineering System Design (NESD)**

Interface that reads impulses of 10^6 neurons, injecting currents to 10^5 neurons, and reading/activating 10^3 neurons.

DARPA [Electrical Prescriptions \(ElectRx\)](#) project enables “artificial modulation of peripheral nerves to restore healthy patterns of signaling in these neural circuits. ElectRx devices and therapeutic systems under development are entering into clinical studies.”

Neural lace i neural dust project for cortex stimulation.

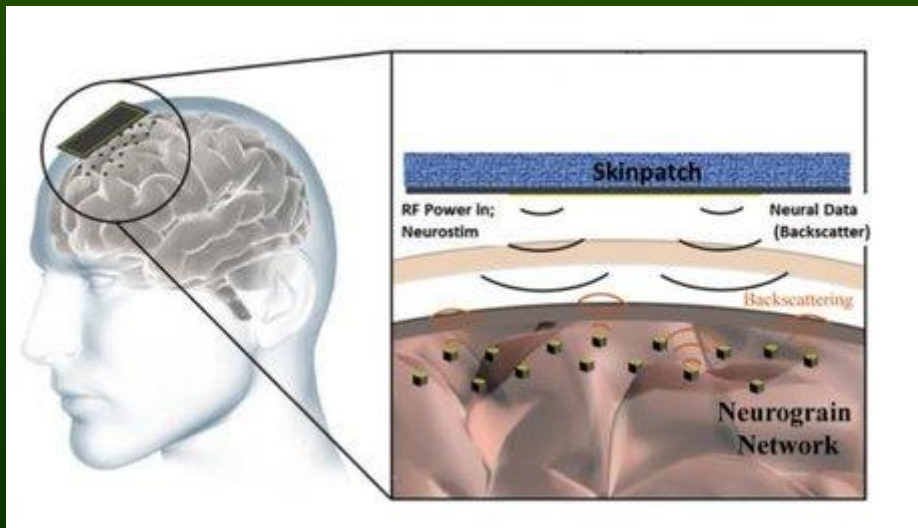

neural
lace
ultra-thin
mesh



Internet of Bodies

Internet of Bodies (IoB) network based on: medical devices (pacemakers, insulin pumps, pulse, SPO2, temperature sensors), consumer tech (wireless earbuds, smartwatches, fitness trackers), all send data beyond the range of the human body, but they can use the common medium of the body itself to send signals.

From: [Turning the Body Into a Wire](#), IEEE Spectrum 11/2020.

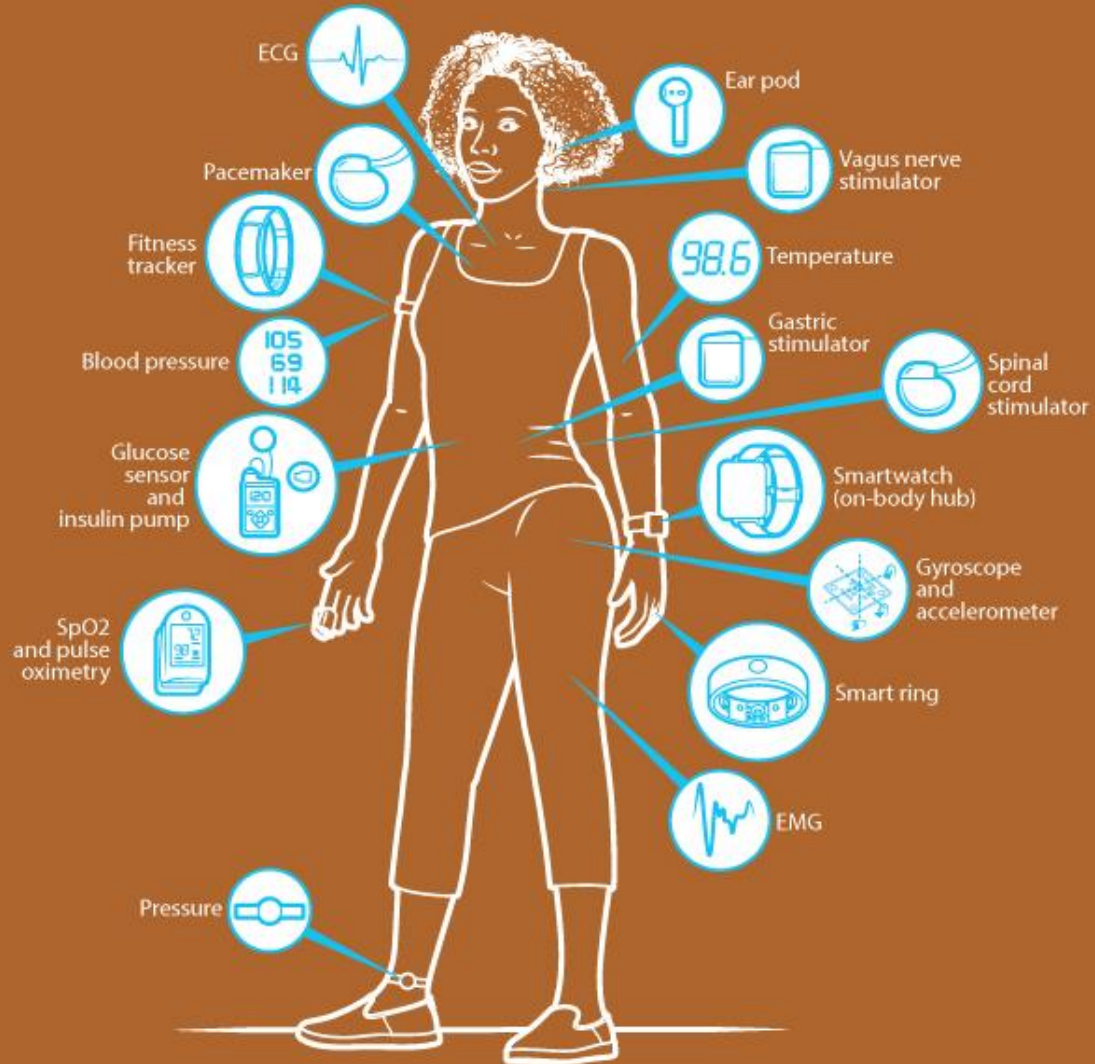

Perspektywy



- Sztuczna inteligencja zmienia sposób uprawiania nauki, nie da się uniknąć dominacji wielkich firm i globalnych konsorcjów.
- To co wczoraj było niemożliwe jutro będzie codziennością, postrzeganie świata i rozumienie języka doprowadzi do autonomicznej formy AI.
- Automatyzacja wymusi wielkie zmiany społeczne.
- 3 wymiary i czas będą dla AI mało interesujące – ewolucja myśli przeniesie się w światy wielowymiarowe, artefakty będą uczyć się szybko od siebie, a nowa wiedza stanie się niezrozumiała dla ludzi.
- Maszyny będą twierdzić, że są świadome, a większość ludzi to akceptuje; prawny status cyborgów jest już teraz dyskutowany.
- Technologie neurokognitywne głęboko zmienią człowieka.
- Dzięki implantom wirtualna rzeczywistość nie będzie się różnić od wrażeń realnych; część osób może się w niej całkiem zagubić; sposób przeżywania swojego istnienia stanie się radykalnie odmienny od obecnego.
- Integracja mózgow z systemami sztucznymi stanie się stopniowo możliwa ...
W końcu **nadejdzie osobliwość!**

Wielka zmiana?

Nie wszyscy zauważyli, że się coś zmieniło.
Polowanie i walka trwa nadal, tylko zniszczenia są coraz większe.



Few Steps Towards Human-like Intelligence

IEEE Computational Intelligence Society Task Force (J. Mandziuk & W. Duch),
Towards Human-like Intelligence.



IEEE SSCI CIHLI 2021 Symposium on Computational Intelligence for Human-like Intelligence, Orlando, FL, USA.

AGI conference, Journal of Artificial General Intelligence comments on Cognitive Architectures and Autonomy: A Comparative Review (eds. Tan, Franklin, Duch).

BICA Annual International Conf. on Biologically Inspired Cognitive Architectures, 11th Annual Meeting of the BICA Society, Natal, Brazil, 2020.

Brain-Mind Institute Schools International Conference on Brain-Mind (ICBM) and Brain-Mind Magazine (Juyang Weng, Michigan SU).

In search of the sources of brain's cognitive activity

Project „Symfonia”, NCN, Kraków, 18.07.2016



FACULTY OF PHYSICS,
ASTRONOMY AND INFORMATICS



CENTRE FOR MODERN
INTERDISCIPLINARY
TECHNOLOGIES

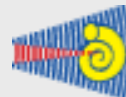

INSTITUTE OF PHYSIOLOGY
AND PATHOLOGY OF HEARING



nencki institute
of experimental biology

Inteligencja?

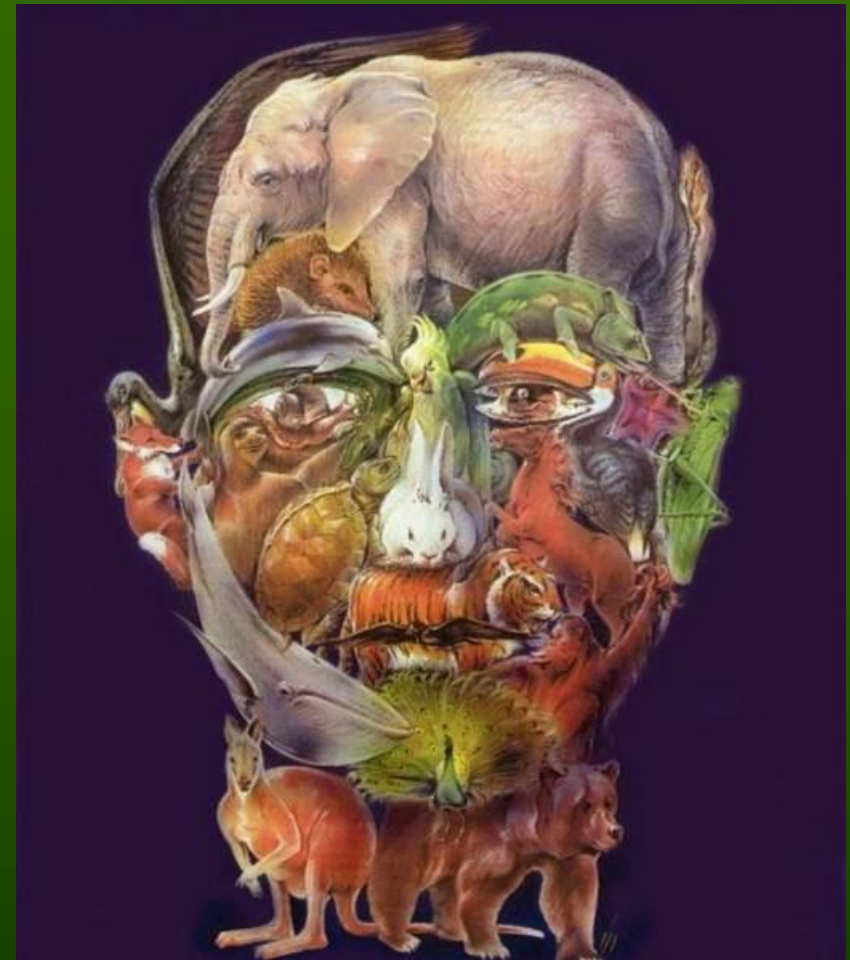

Google: Wlodek Duch
=> referaty, prace, wykłady ...