



*Imaging and spectral information with
time-domain OCT
Application to works of art*

Gaël Latour

Institut des Nanosciences de Paris (INSPI)

gael.latour@insp.jussieu.fr

Latour et al., Applied Optics, in submission

OCT4ART – Torun, Poland – 3-5 July 2008

Optical techniques to study works of art

Purpose: *obtaining information from the studied work of art*

- ✓ Pigment
- ✓ Dye
- ✓ Varnish
- ✓ Surface state
- ✓ Number of layers
- ✓ Thickness of a layer
-

Interest of the optical techniques:

non destructive and without any contact analysis

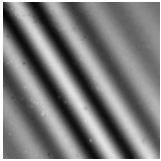

Time-domain OCT: imaging and spectral information

Overview

✓ Setup

✓ Acquisition and processing

✓ Imaging: painting

✓ Imaging: music instruments

✓ Spectral information

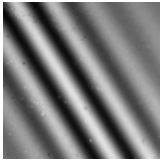

Setup Michelson interferometer

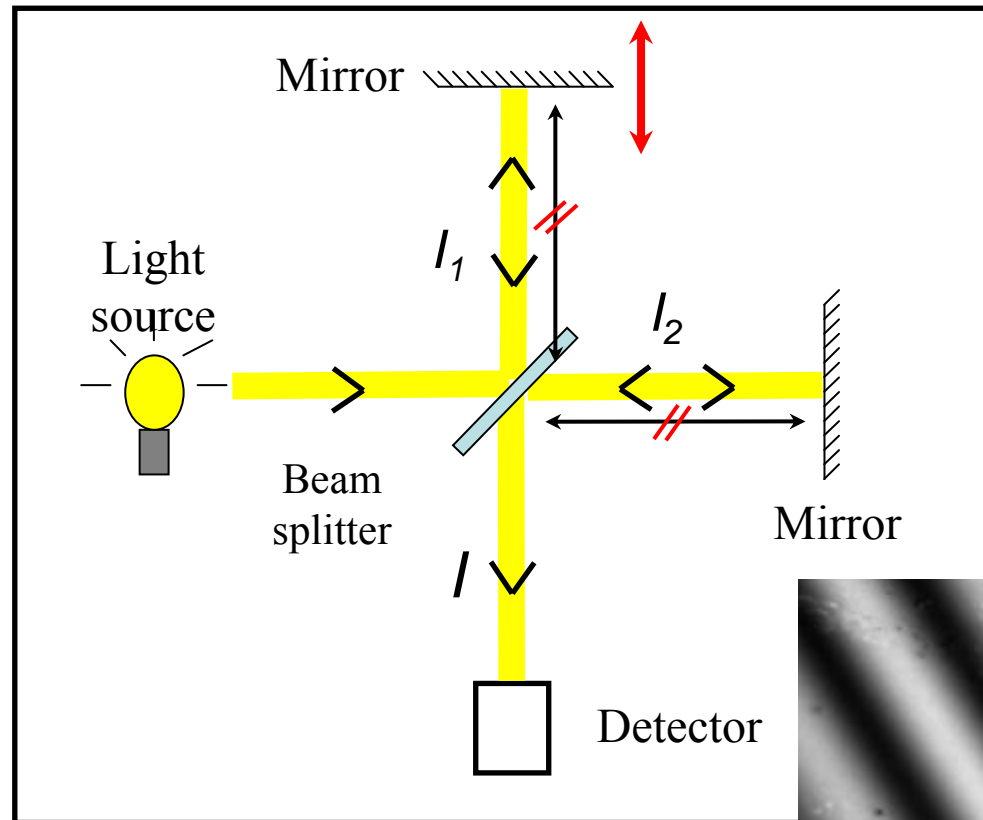

Equal optical paths

 Interference pattern

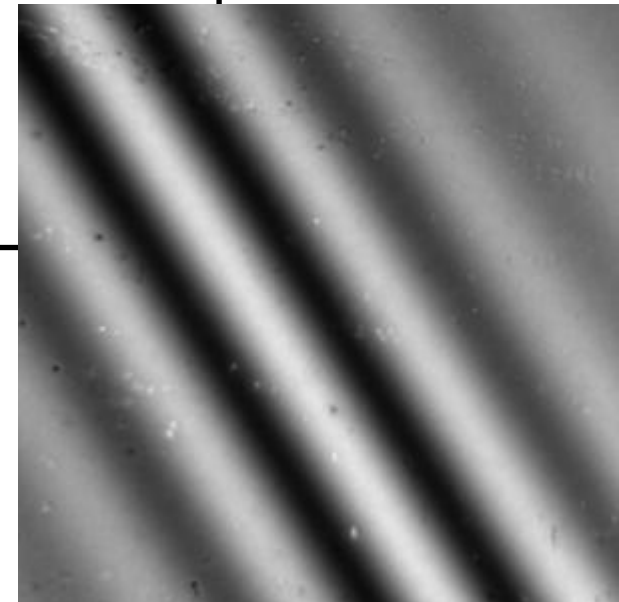

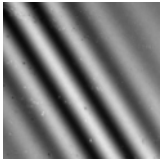

Setup Setup at the INSP

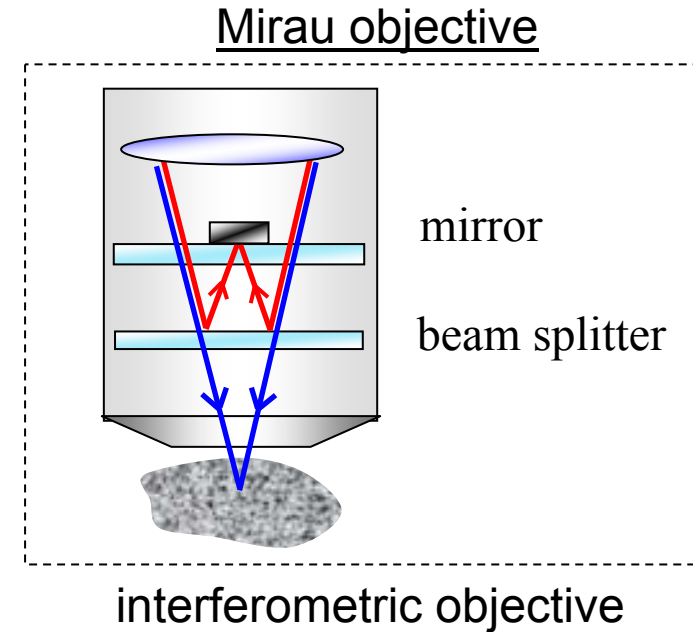
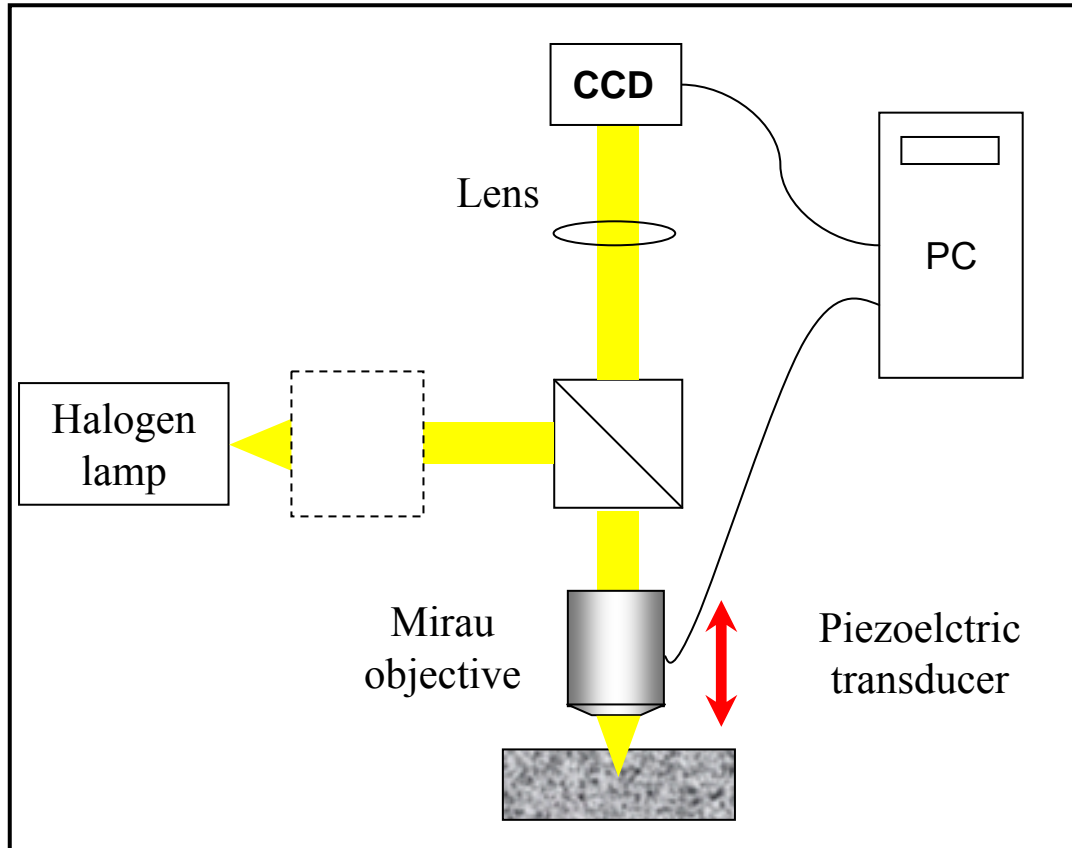

- ✓ Sensitive in the visible range
- ✓ Stability of the device

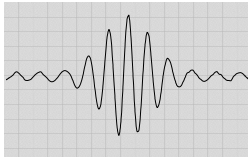

Time-domain OCT: imaging and spectral information

Overview

- ✓ Setup
- ✓ Acquisition and processing
 - ✓ Imaging: painting
 - ✓ Imaging: music instruments
 - ✓ Spectral information

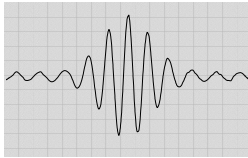

Acquisition and processing

Acquisition

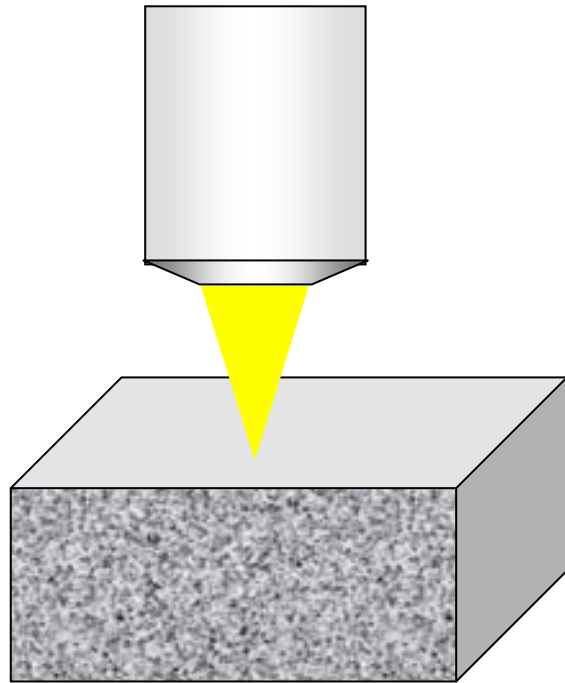

For each position of the objective, one image is recorded

$$\Delta z \sim 30 \text{ nm}$$

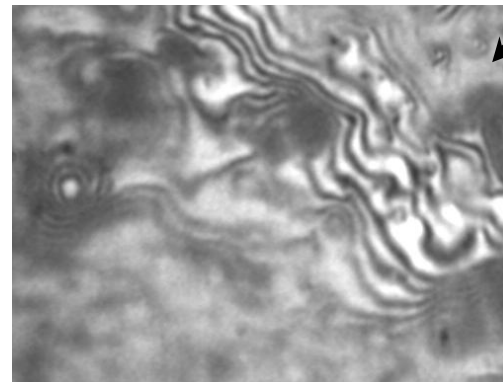
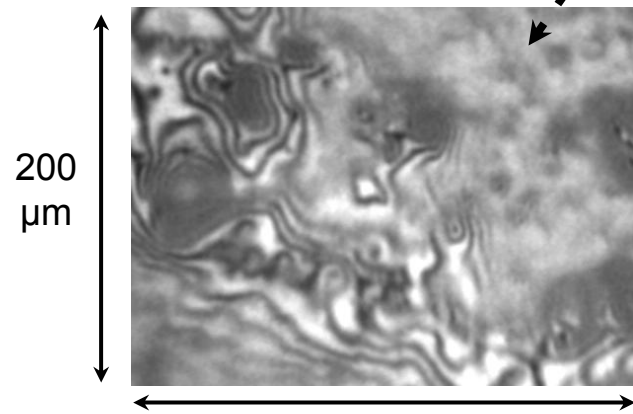
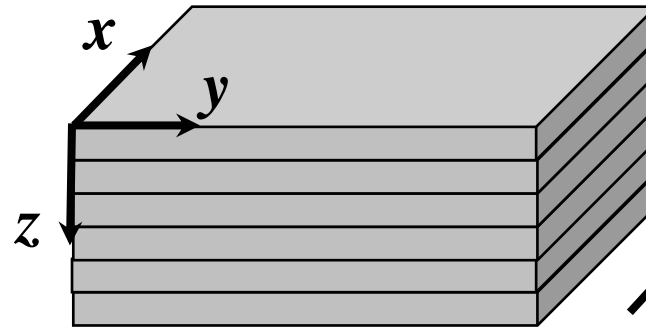

Lateral resolution
 $\sim 2 \mu\text{m}$

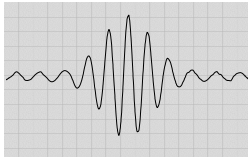

Acquisition and processing Imaging

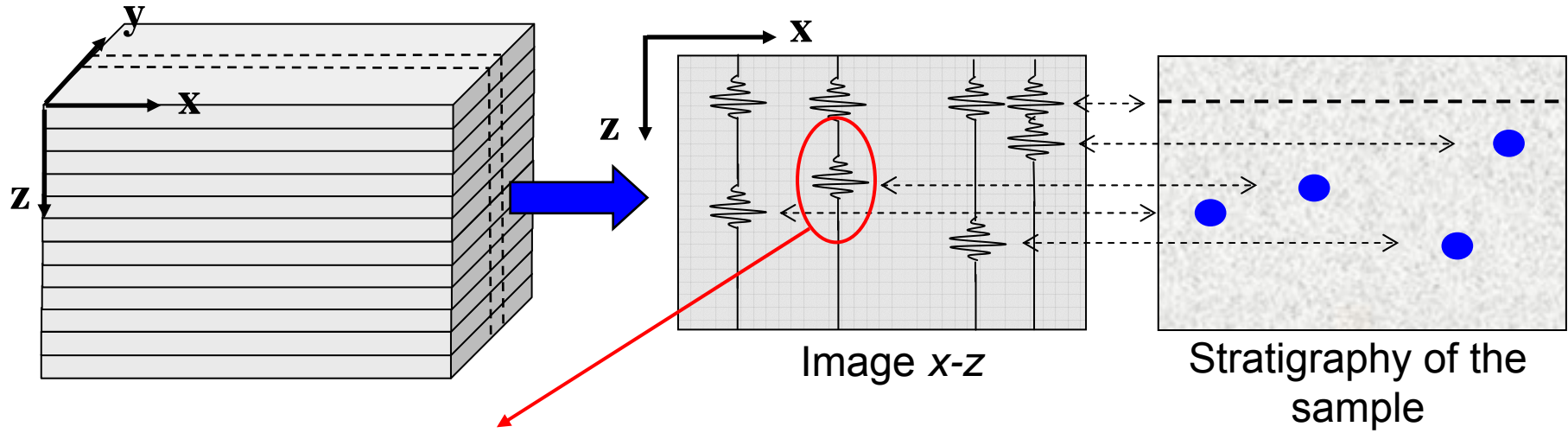

Interferogram

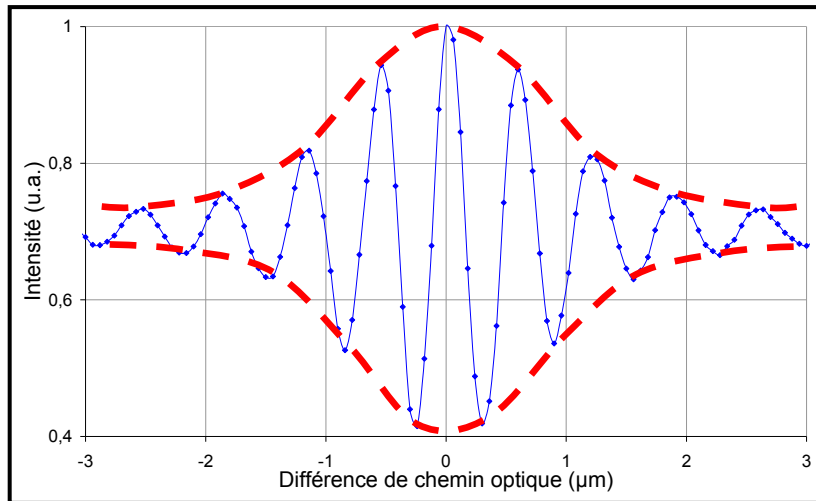

Envelop

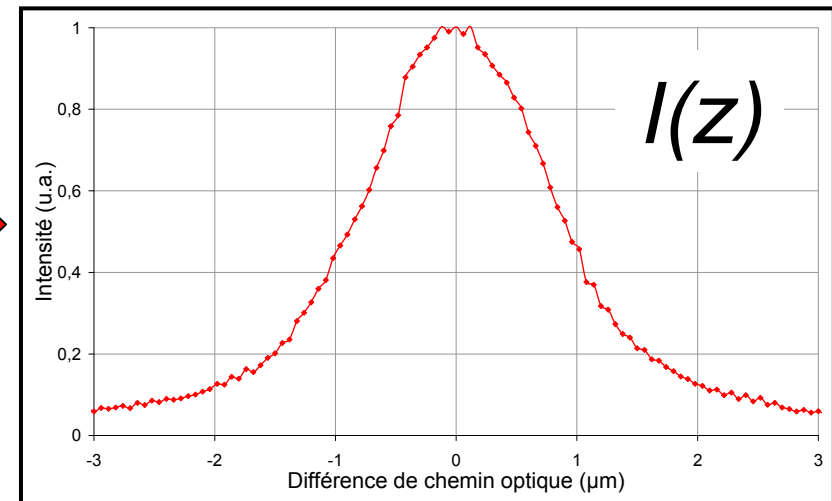



Time-domain OCT: imaging and spectral information

Overview

- ✓ Setup
- ✓ Acquisition and processing
 - ✓ Imaging: painting
 - ✓ Imaging: music instruments
 - ✓ Spectral information



Imaging: painting

Imaging: one pictorial layer

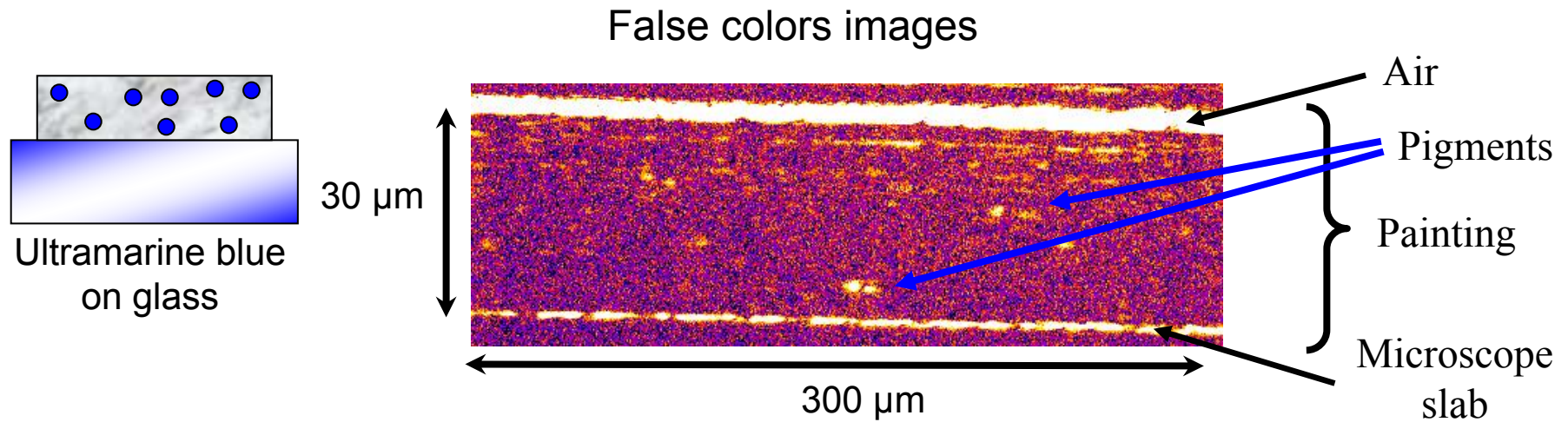

From axial slices, reconstruction of 3D imaging

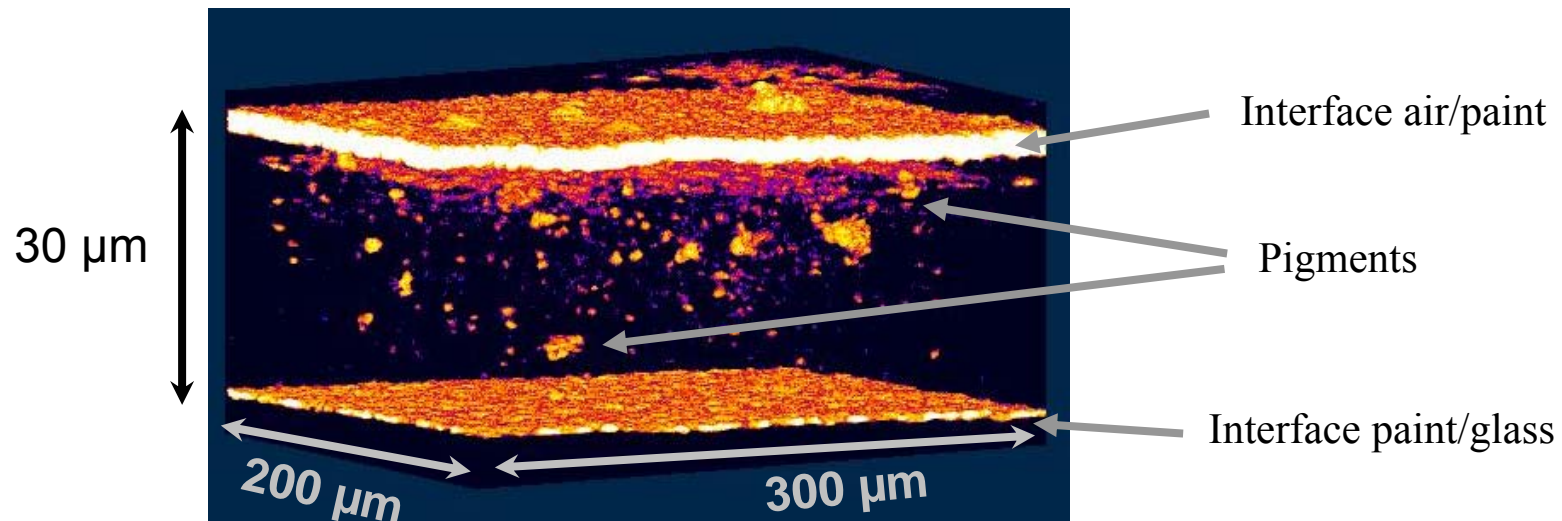



Imaging: painting

Imaging: stratified layers

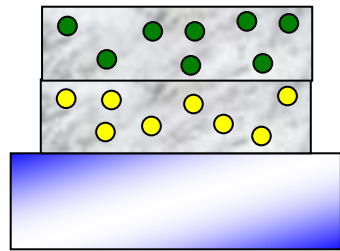

Viridian green on chrome yellow

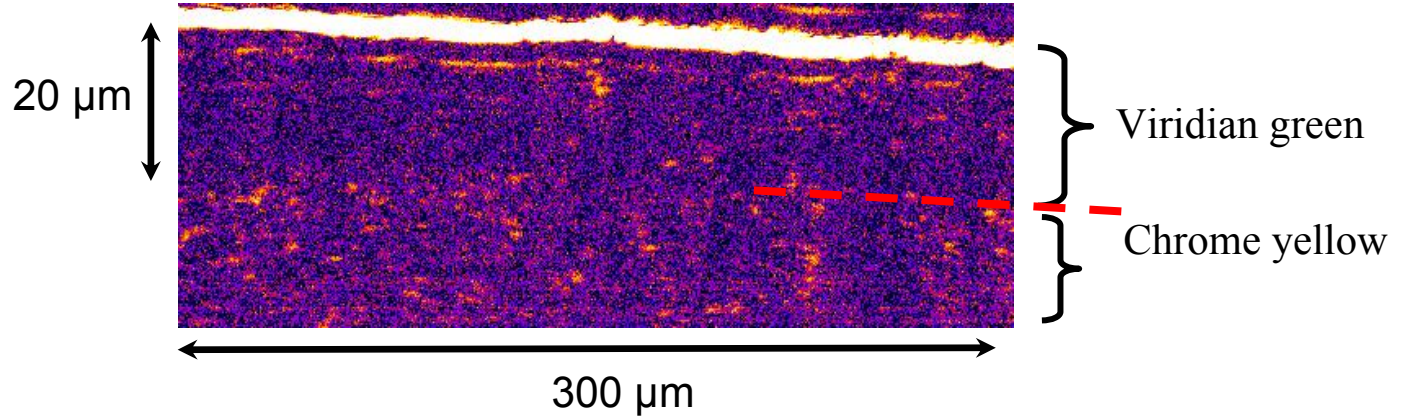

3D Image

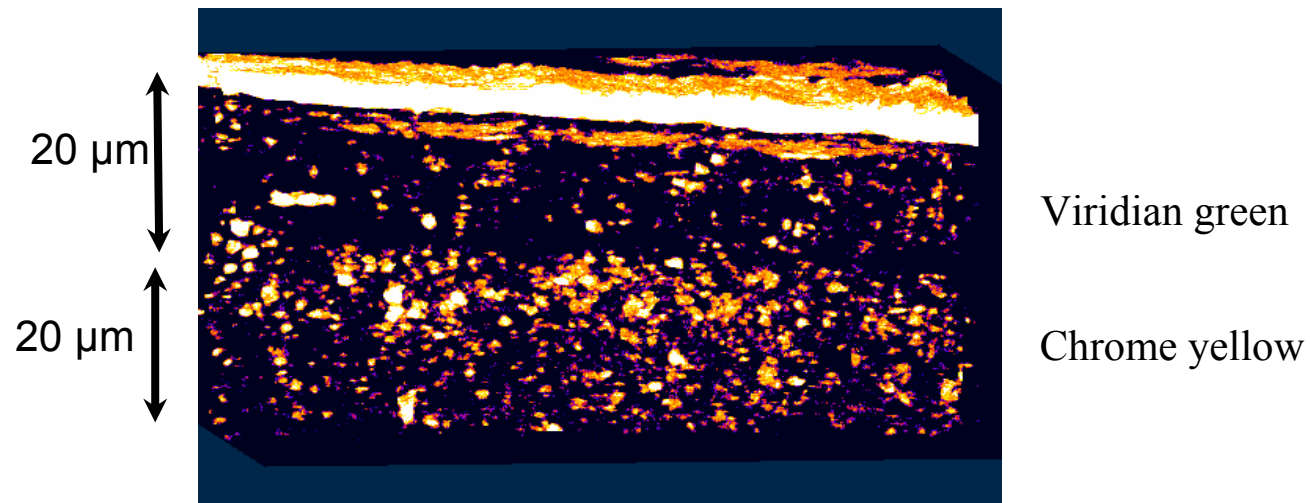

 Imaging of stratified layers



Imaging: painting

Imaging: varnished paint layer



Varnish

Viridian green

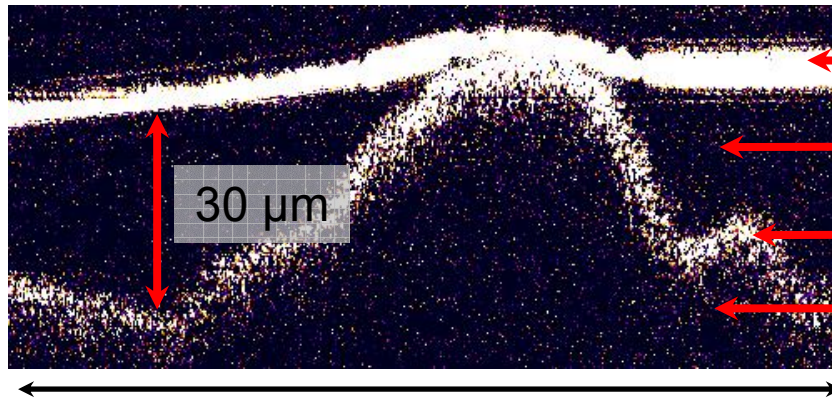

Interface air/varnish

Varnish

Interface varnish/paint

Painting

300 μm

3D Images

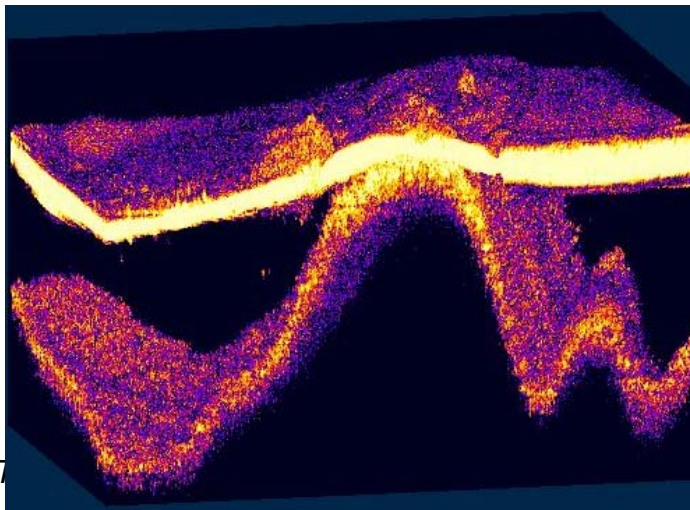

OCT4ART

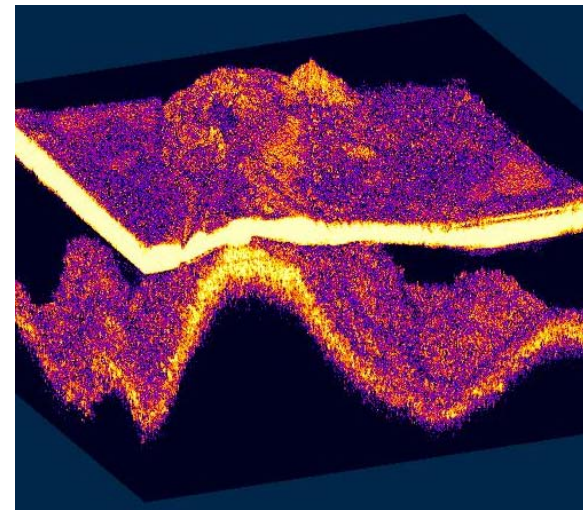

Gaël Latour



Time-domain OCT: imaging and spectral information

Overview

- ✓ Setup
- ✓ Acquisition and processing
 - ✓ Imaging: painting
- ✓ **Imaging: music instruments**
 - ✓ Spectral information



Imaging: music instruments

Wood instruments: violin, cello...

Precious and delicate objects

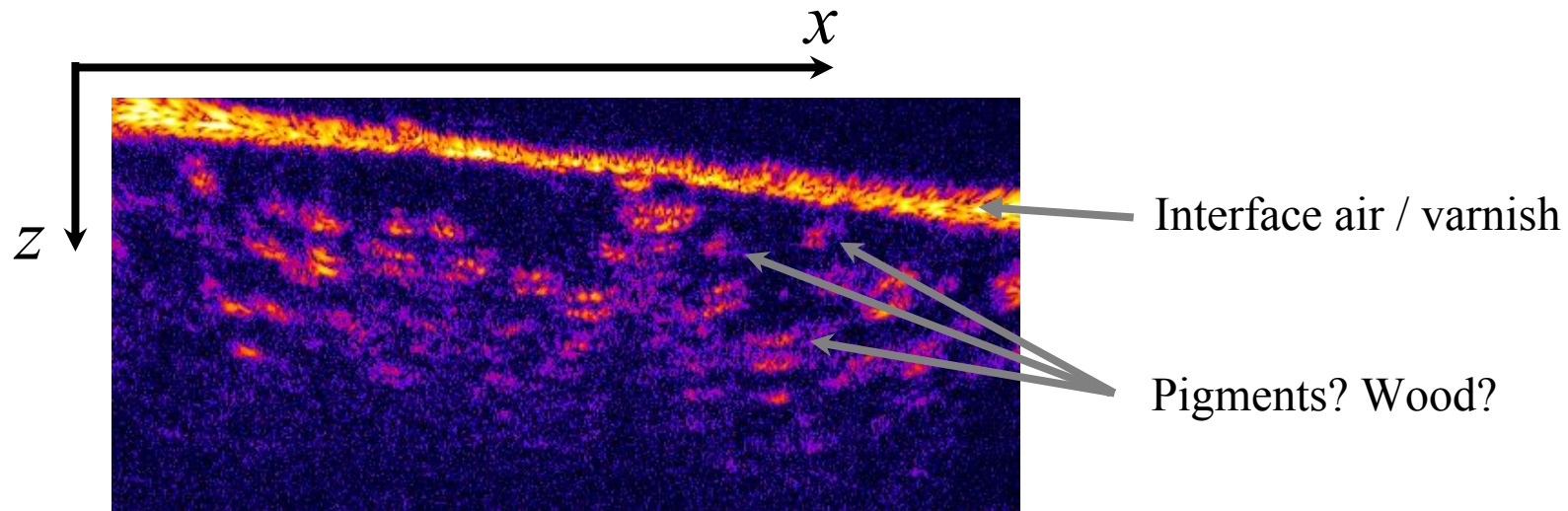

Stratified layers?

Presence of pigments?

Interface varnish / wood?



Imaging: Music instruments

OCT: device for the study of music instruments?

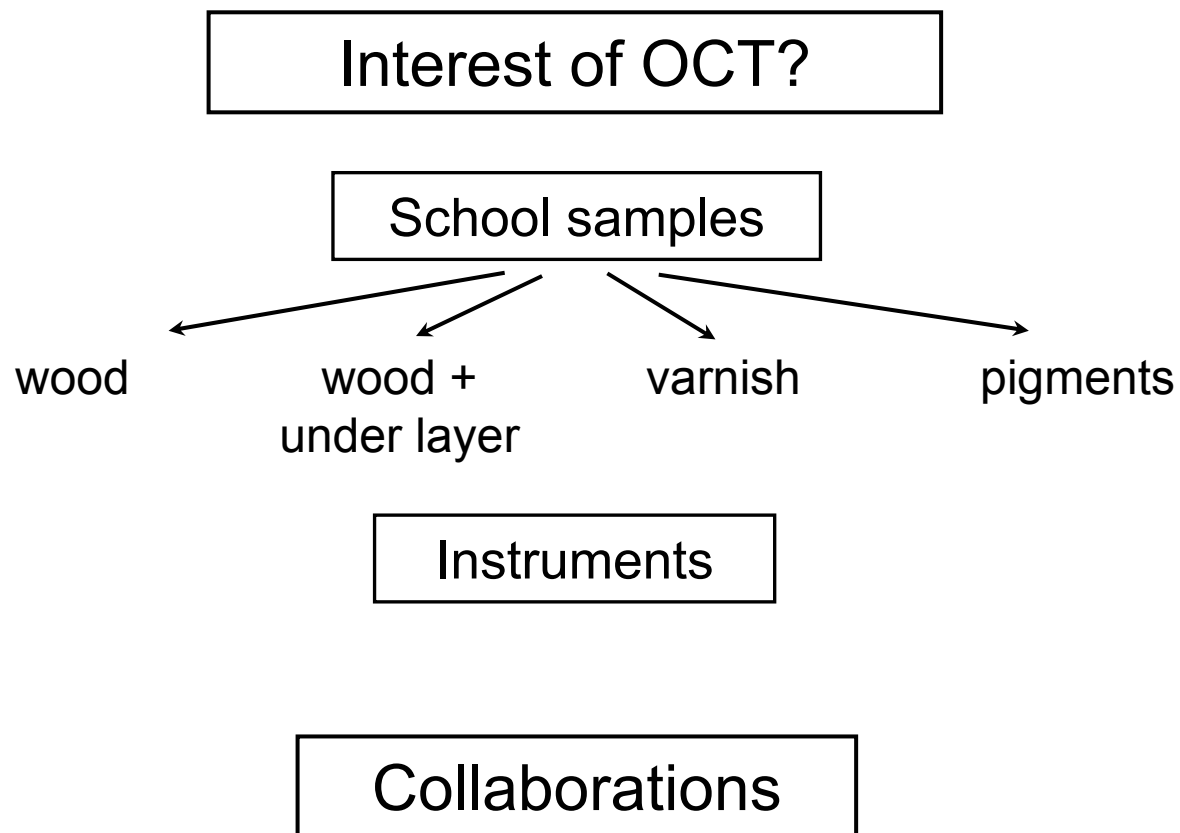

Music Museum Laboratory
Jean-Philippe Echard
Stéphane Vaiedelich
(Cité de la Musique, Paris)

Conservator and violin maker
Balthazar Soulier
(Staatliche Akademie der Bildenden
Künste, Stuttgart)



Imaging: Music instruments Wood

*Among the wood species:
choice of maple*

Back, headpiece and rib



Landolfi, Milan, XVIIIth (private collection)



Imaging: Music instruments

Wood: maple

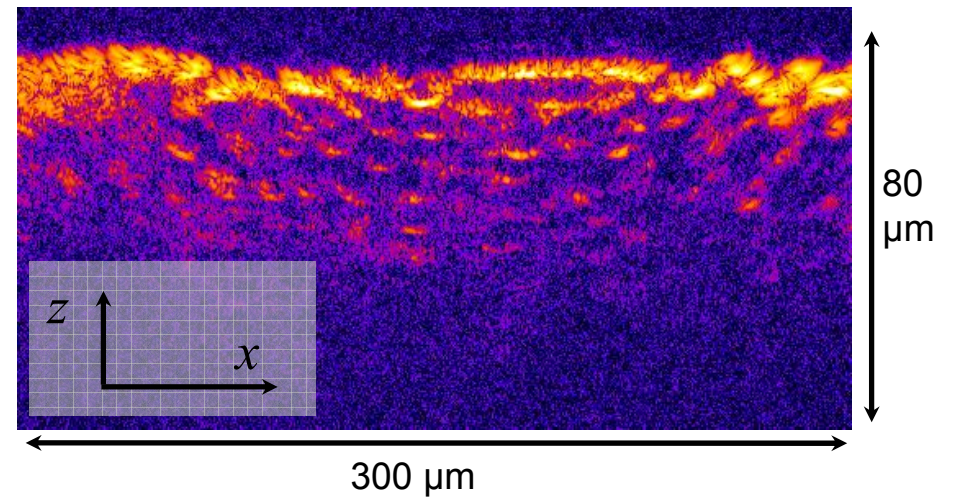
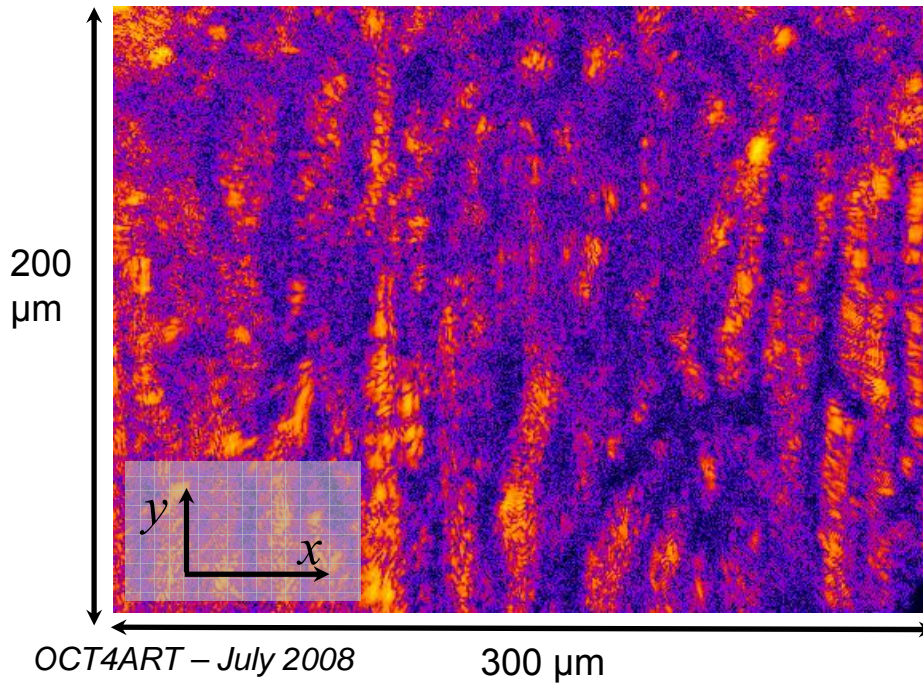
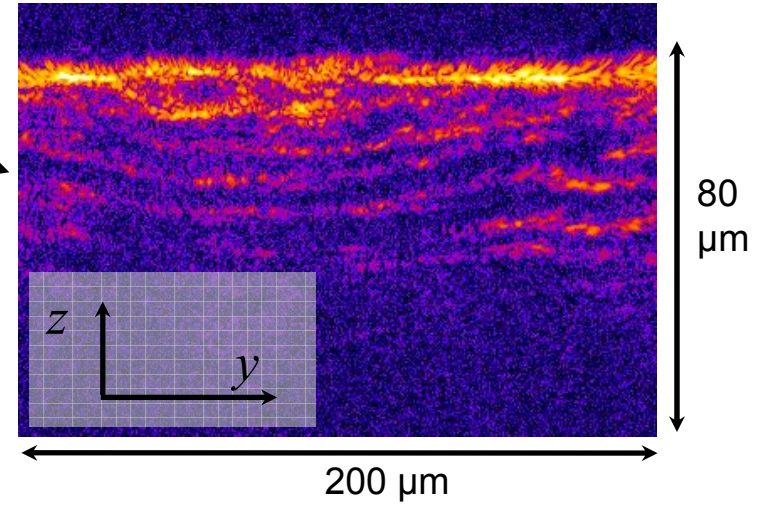
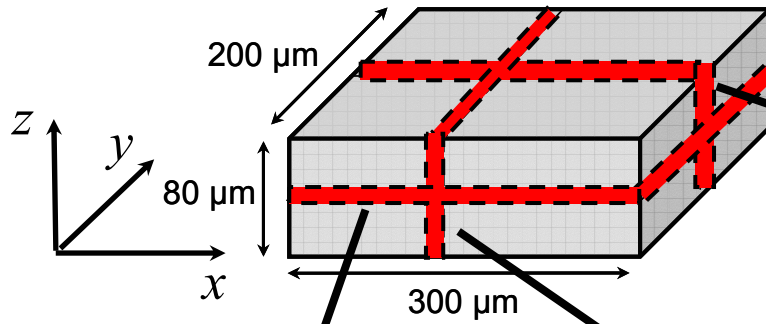

Gaël Latour



Imaging: Music instruments

Wood + under layer + varnish

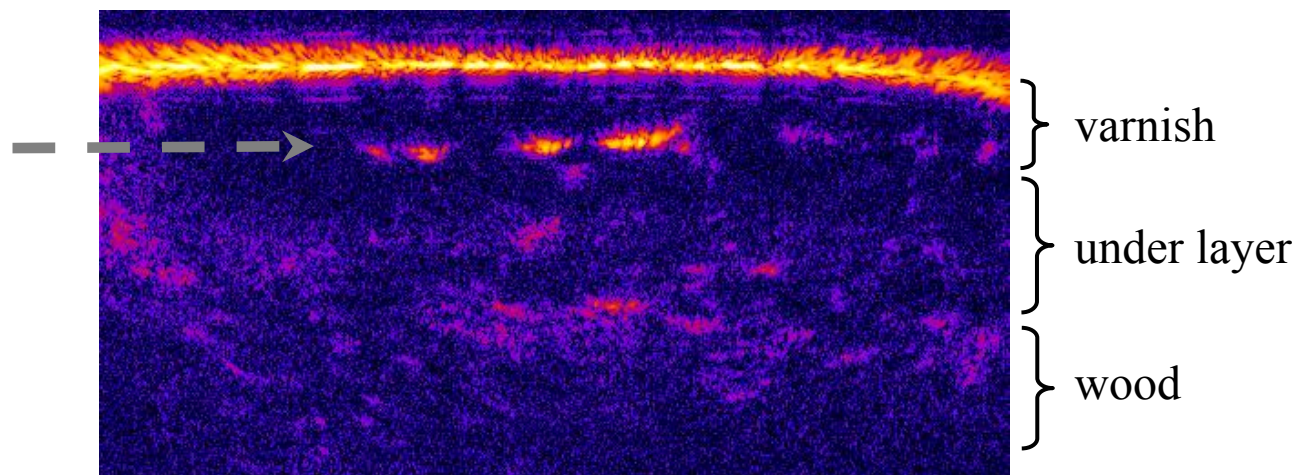
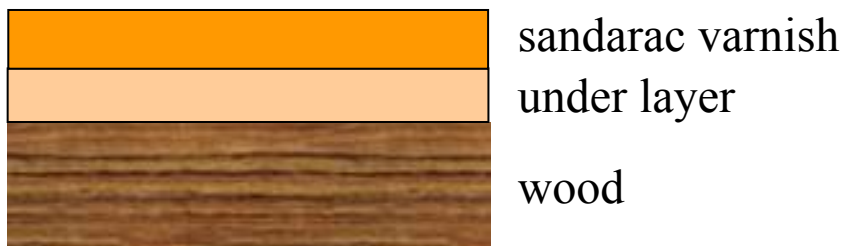

 interface between varnish and under layer



OCT: imaging

Painting

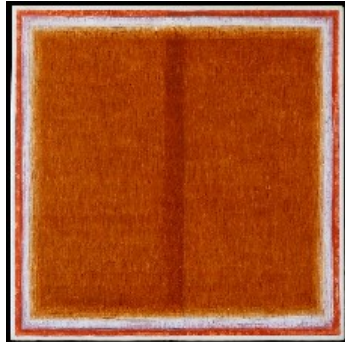

Music instruments



and ...

- Number of layers
 - Thicknesses
 - Surface state
 - Presence of fillers
- Informations about the wood

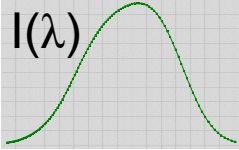

Time-domain OCT: imaging and spectral information

Overview

- ✓ Setup
- ✓ Acquisition and processing
 - ✓ Imaging: painting
- ✓ Imaging: music instruments
 - ✓ Spectral information



Spectral information from OCT

Spectral information



Glass

Interferogram

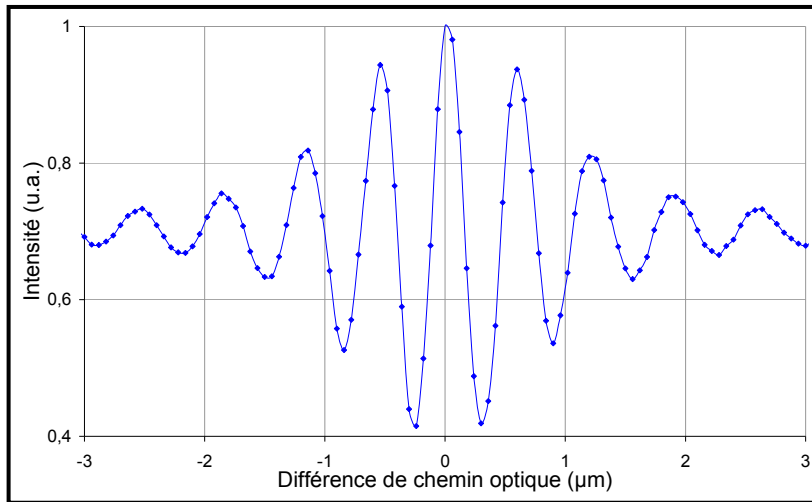

Fourier Transform

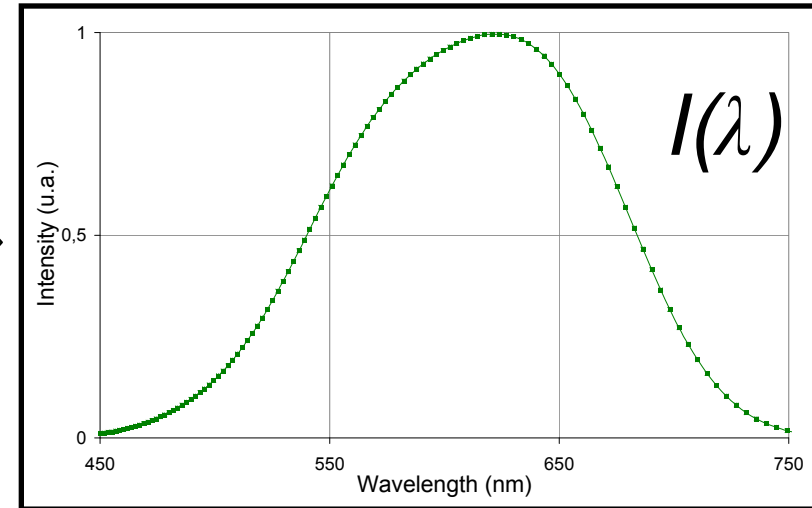

Spectral transfer function of the device

Central wavelength ~ 620 nm

Spectral width ~ 150 nm

Spectral resolution: 2 to 5 nm



Spectral information from OCT
Spectral information: dye

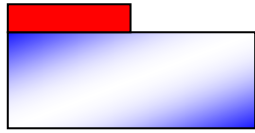

Red dye on glass

Absorbing and non diffusing medium

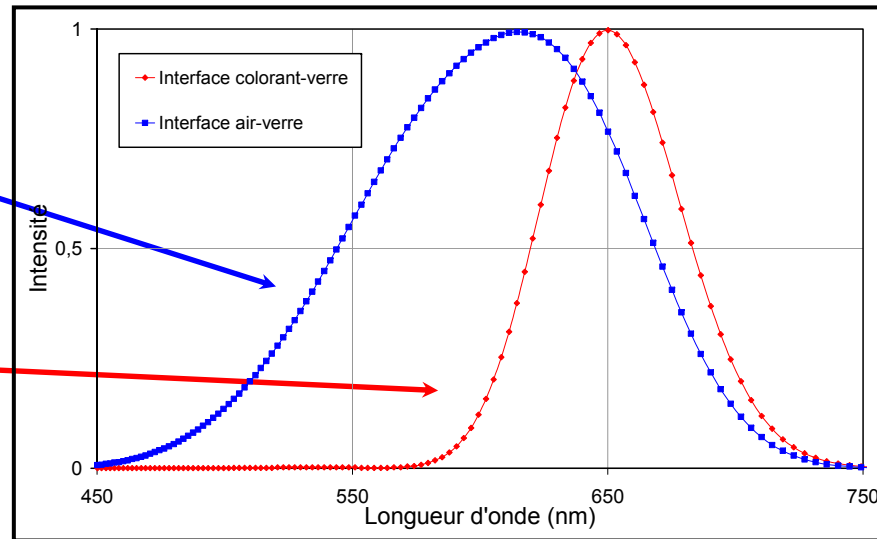
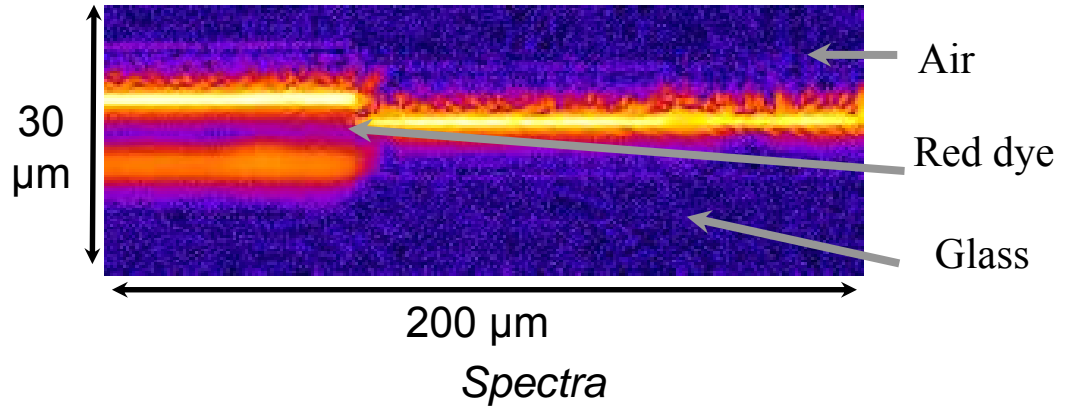
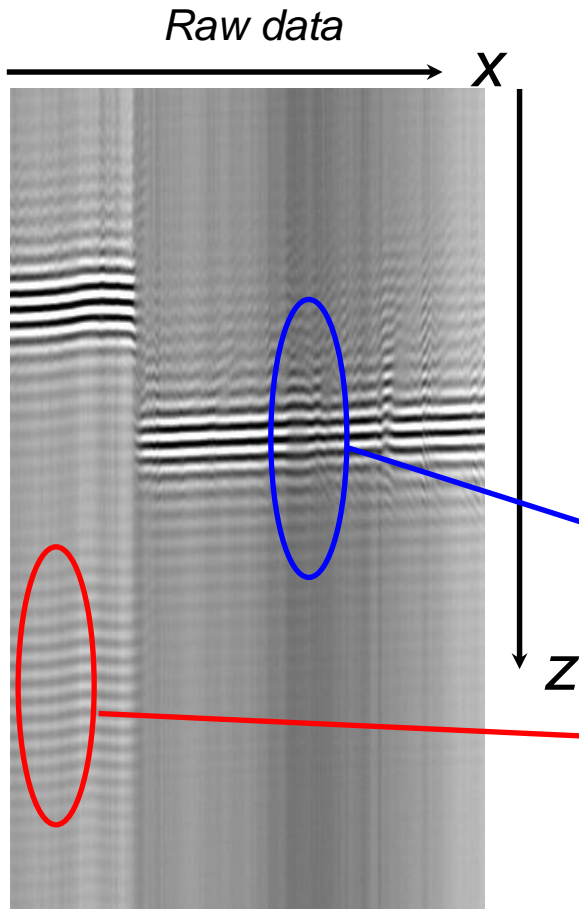

→ Reproducible spectra

→ OCT spectrum = transmittance spectrum



Spectral information from OCT

Spectral information: pictorial layer

Diffusing medium

Spectra obtained after FT

Spectra of several pigments

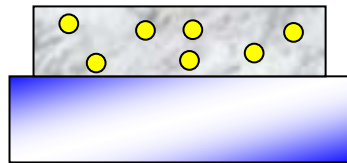

Chrome yellow painting

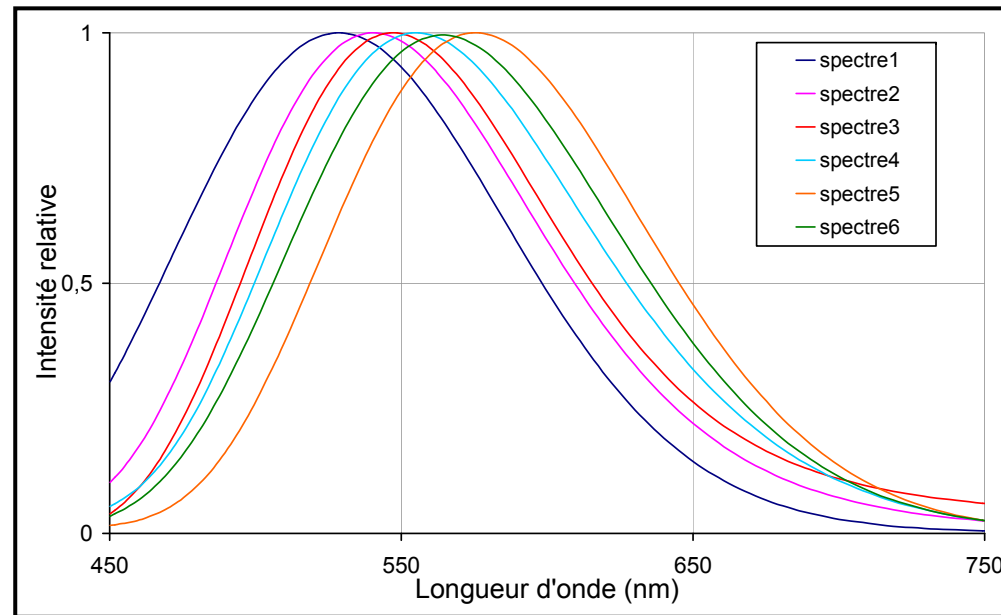

➔ Spectra from several pigments are different

Outlook:

➔ Obtaining reproducible spectra

OC ➔ Identification of pigments by comparison with a database of spectra



OCT applied to works of art



➤ *Time-domain OCT*

- ➔ Axial resolution: 1,5 μm
- ➔ Sensitive in the visible range



➤ *3D Imaging*



- ➔ Thickness of a varnish
- ➔ Thicknesses of layers
- ➔ Presence of fillers
- ➔ ...

➤ *Spectral information*

- ➔ Validation on dyes

➤ *Outlook*

- ➔ Spectral information on pigments

Aknowledgements:

Isabelle Emond (INSP),

Jean-Philippe Echard and Stéphane Vaiedelich (Cité de la Musique, Paris)

Balthazar Soulier (SABK, Stuttgart)

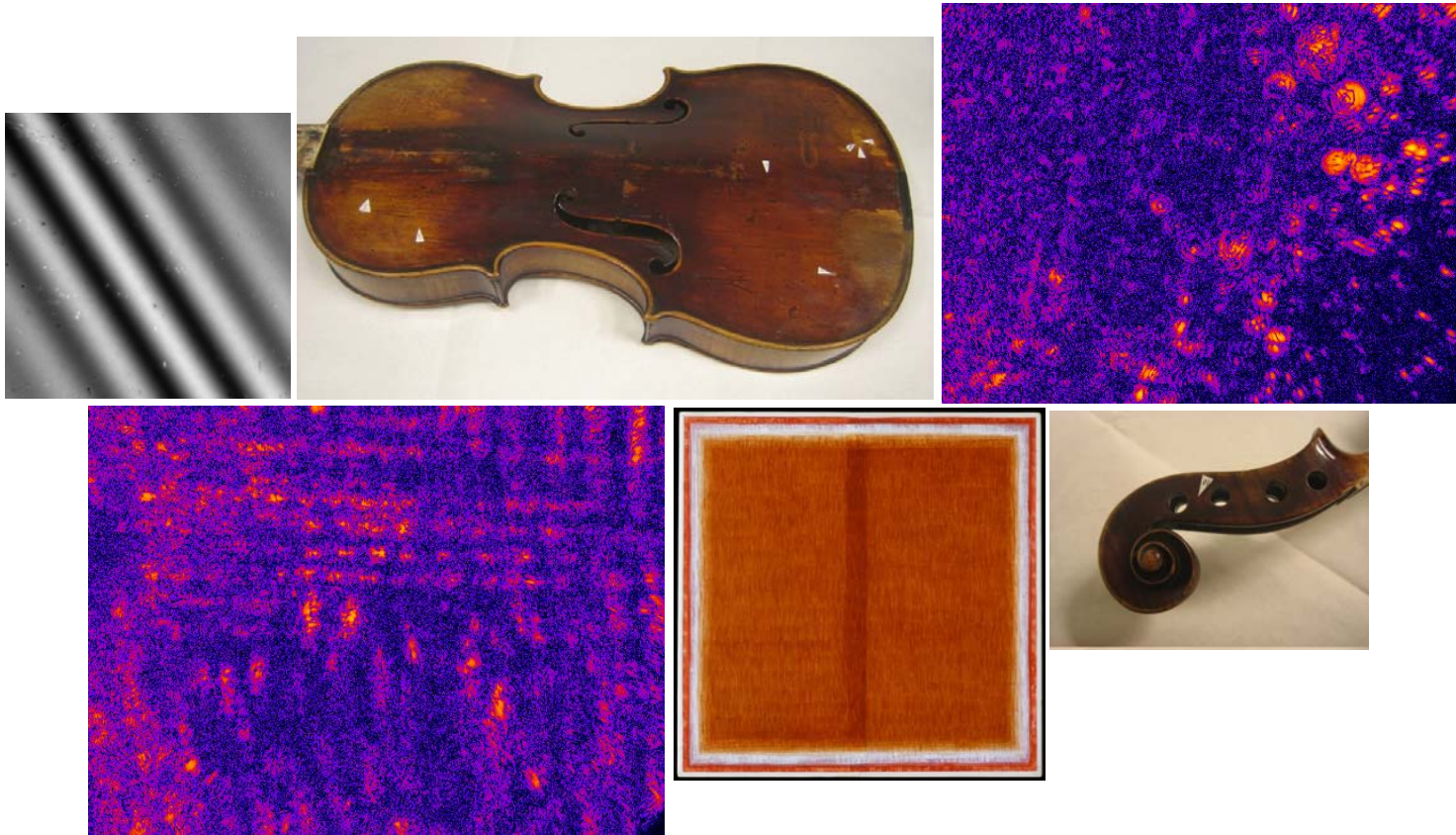

Thank you for your attention ...